

FÉDÉRATION AÉRONAUTIQUE INTERNATIONALE

**SPORTING CODE
SECTION IV**



2002 Edition

Effective February 10, 2002

VOLUME ABR

SECTION 4A, SECTION 4B, SECTION 4C

SECTION 4A - CIAM INTERNAL REGULATIONS
SECTION 4B - GENERAL RULES FOR INTERNATIONAL CONTESTS
SECTION 4C - GENERAL REGULATIONS AND RULES FOR CONTESTS
AND RECORDS

THIS EDITION INCLUDES THE FOLLOWING AMENDMENTS MADE TO 2001 CODE

Paragraph	Plenary meeting approving change	Brief description of change	Change incorporated by
4.A – Part One	2001	Use of terms (in Introduction)	R. Underwood
A.9	2001	Date to receive sanction	R. Underwood
Annex A.2	-	Nomination form for the A. Tupolev medal had been inadvertently omitted in the 2001 edition	FAI Secretariat
B5.2.	2001	Awarding Championships	R. Underwood
B.6.4.	2001	Maximum event fees	R. Underwood
3.2.2	2001	Exception to event fees	R. Underwood

FEDERATION AERONAUTIQUE INTERNATIONALE

Avenue Mon Repos 24, 1005 LAUSANNE, Switzerland

Copyright 2002

All rights reserved. Copyright in this document is owned by the Fédération Aéronautique Internationale (FAI). Any person acting on behalf of the FAI or one of its Members is hereby authorised to copy, print, and distribute this document, subject to the following conditions:

- 1. The document may be used for information only and may not be exploited for commercial purposes.**
- 2. Any copy of this document or portion thereof must include this copyright notice.**

RIGHTS TO FAI INTERNATIONAL SPORTING EVENTS

All international sporting events organised wholly or partly under the rules of the Fédération Aéronautique Internationale (FAI) Sporting Code¹ are termed *FAI International Sporting Events*². Under the FAI Statutes³, FAI owns and controls all rights relating to FAI International Sporting Events. FAI Members⁴ shall, within their national territories⁵, enforce FAI ownership of FAI International Sporting Events and require them to be registered in the FAI Sporting Calendar⁶.

Permission and authority to exploit any rights to any commercial activity at such events, including but not limited to advertising at or for such events, use of the event name or logo for merchandising purposes and use of any sound and/or image, whether recorded electronically or otherwise or transmitted in real time, must be sought by way of prior agreement with FAI. This includes specifically all rights to the use of any material, electronic or other, that forms part of any method or system for judging, scoring, performance evaluation or information utilised in any FAI International Sporting Event⁷.

Each FAI Air Sport Commission⁸ is authorised to negotiate prior agreements on behalf of FAI with FAI Members or other entities as appropriate, of the transfer of all or parts of the rights to any FAI International Sporting Event (except World Air Games events⁹) which is organised wholly or partly under the Sporting Code section¹⁰ for which that Commission is responsible¹¹. Any such transfer of rights shall be by “Organiser Agreement”¹² as specified in the current FAI Bylaws Chapter 1, para 1.2 “Rules for Transfer of Rights to FAI International Sporting Events”.

Any person or legal entity which accepts the responsibility for organising an FAI Sporting Event, whether or not by written agreement, in doing so also accepts the proprietary rights of FAI as stated above. Where no formal transfer of rights has been established, FAI retains all rights to the event. Regardless of any agreement or transfer of rights, FAI shall have, free of charge for its own archival and/or promotional use, full access to any sound and/or visual images of any FAI Sporting Event, and always reserves itself the right to have any and all parts of any event recorded, filmed and/or photographed for such use, without charge.

1 FAI Statutes, Chapter 1, para. 1.6

2 FAI Sporting Code, General Section, Chapter 3, para 3.1.3.

3 FAI Statutes, Chapter 1, para 1.8.1

4 FAI Statutes, Chapter 5, para 5.1.1.2; 5.5; 5.6 and 5.6.1.6

5 FAI Bylaws, Chapter 1, para 1.2.1

6 FAI Statutes, Chapter 2, para 2.3.2.2.5,

7 FAI Bylaws, Chapter 1, para 1.2.3

8 FAI Statutes, Chapter 5, para 5.1.1.2; 5.5; 5.6, 5.6.1.6

9 FAI Sporting Code, General Section, Chapter 3, para 3.1.7

10 FAI Sporting Code, General Section, Chapter 1, paras 1.2. and 1.4

11 FAI Statutes, Chapter 5, para 5.6.3

12 FAI Bylaws, Chapter 1, para 1.2.2

PAGE DELIBERATELY LEFT BLANK

INTRODUCTION TO SPORTING CODE SECTION 4

Sporting Code Section 4 contains the rules and regulations for FAI recognised activities in model aircraft and space models. These regulations are the responsibility of the FAI Aeromodelling Commission (CIAM) and complement the General Section which contains the rules and regulations common to all FAI activities.

Section 4 is split into volumes to ease downloading the regulations for specific activities. Volume ABR gives the General Rules for CIAM activities, competitions and records that are applicable for each activity. The specific volumes contain all CIAM documents for the activity concerned: Official classes, World Cup rules, provisional classes, guides for organisers and judges. The specific activities and related volumes are shown in the table below.

ACTIVITY	VOLUME
General rules for CIAM Activities, Competitions and records	ABR
Model aircraft competitions	
• Free Flight	F1
• Control Line	F2
• RC Aerobatics	F3A
• RC Soaring	F3BJ
• RC Helicopter	F3C
• RC Pylon Racing	F3D
• Scale Model Aircraft	F4
• RC Electric Powered	F5
Space Models Competitions and Records	SM

The use of “shall” and “must” implies that the aspect concerned is mandatory. The use of “should” implies a non mandatory recommendation ; “may” implies what is permitted or what might happen, and “will” indicates what is going to happen. Words of masculine gender should be taken as including the feminine gender unless the context indicates otherwise. Italics are used for explanatory notes.

PAGE DELIBERATELY LEFT BLANK

VOLUME ABR
GENERAL RULES FOR CIAM ACTIVITIES

SECTION 4A – CIAM INTERNAL REGULATIONS

- A.1 CIAM Plenary Meeting
- A.2 Procedure for CIAM Plenary Meeting
- A.3 Bureau
- A.4 Subcommittees
- A.5 Forms of Subcommittee Work
- A.6 Proposals Submitted to the CIAM
- A.7 Timetables for Reports and Proposals
- A.8 Languages
- A.9 Contest Calendar
- A.10 Judges List
- A.11 List of Technical Experts
- A.12 Effective Date of Rule Changes
- A.13 Aeromodelling Fund
- A.14 Changing from Provisional to Official Rules

Annex A.1 – Guide for submitting World and Continental Championship Proposals to CIAM for approval

Annex A.2 – Forms :

- Nomination of Judges
- Nomination of Technical Experts
- Contest registration
- Judges nominations
- Technical experts nominations
- Nominations of CIAM office holders
- Rule change proposal
- Nominations for CIAM awards and diplomas

SECTION 4B – GENERAL RULES FOR INTERNATIONAL CONTESTS

- B.1 General Definition for International Contests
- B.2 Types of International Contests
- B.3 Competitors and Teams
- B.4 Contest Officials
- B.5 Organisation of International Contests
- B.6 Contest Information and Entry Fees
- B.7 Special Contest Organisation Requirements
- B.8 Radio Control
- B.9 Timing

- B.10 Duration of the Contest
- B.11 Interruption of the Contest
- B.12 Classification and Awards at World Championships
- B.13 Processing of the Model Characteristics
- B.14 Protests
- B.15 Safety Precautions and Instructions
- B.16 Disqualification from the Contest
- B.17 FAI Championship Trophies

Annex B.2 – Aircraft Nationality and Registration Marks

SECTION 4C – MODEL AIRCRAFT

General Regulations and Rules for Contest and Records

PART ONE – GENERAL REGULATIONS FOR MODEL AIRCRAFT

- 1.1 General Definition of Model Aircraft
- 1.2 General Characteristics of Model Aircraft
- 1.3 Classification of Model aircraft
- 1.4 Definitions of the Expressions used for Model Aircraft Specifications and Rules

PART TWO – GENERAL RULES FOR INTERNATIONAL CONTESTS

- 2.1 World Championship Events for Model Aircraft
- 2.2 Organisation of International Contests
- 2.3 Processing of Model Characteristics and Number of Models

PART SEVEN – RECORDS

- 7.1 World Class Records
 - 7.2 General Specifications of Model aircraft for Record Attempts
 - 7.3 Special Rules for Duration Records
 - 7.4 Special Rules for Distance Records in a Straight Line
 - 7.5 Special Rules for Speed Records in a Straight Line
 - 7.6 Special Rules for Speed Records in a Closed Circuit
 - 7.7 Special Rules for Speed Records in a Circular Flight
 - 7.8 Special Rules for Altitude Records
 - 7.9 Special Rules for Distance in Closed Circuit records
 - 7.10 Dossier of a Record Attempt
 - 7.11 Supporting Data
- Table I Classification of records
- Table II Application for record attempt confirmation – model aircraft
- Table III Record Dossier Check Form (Model aircraft)

VOLUME ABR

SECTION 4A

PART ONE - CIAM INTERNAL REGULATIONS

A.1. CIAM PLENARY MEETING

- A.1.1. The Plenary Meeting of the CIAM shall convene once a year in March or at such other times as shall be decided by the President of the CIAM. The meeting will be held at the FAI in Lausanne, if no special advantages are to be found elsewhere, subject to the approval of the Secretary General of FAI.
- A.1.2. The Agenda for the meeting is prepared by the CIAM Secretary in agreement with the President of the CIAM, and distributed by the FAI Office.
- A.1.3. The Agenda shall include proposals drawn up in the manner required in paragraphs A.6 and A.12. The Agenda shall be despatched to the NAC's and the officers of the Bureau with the notice convening the meeting not later than 45 days before the meeting. If the Agenda is not sent out in proper time, the Plenary Meeting may be postponed by the President.

A.2. PROCEDURE FOR CIAM PLENARY MEETINGS

- A.2.1. On the first day there will be preliminary technical meetings held by the chairmen of the appropriate Subcommittees. These meetings shall consider items in the agenda for the purpose of discussion and briefing of all those present and shall make their recommendations thereon to the Plenary Meeting. Eligible to attend are subcommittee members, voting delegates, alternates and any others approved by their National Airsports Controls. Among those eligible to attend only one per country may vote; subcommittee members are also eligible to vote in the technical meetings.
- A.2.2. The President may add to the Agenda, any matter considered being urgent.
- A.2.3. The minutes of the plenary meeting are to be drafted by the Secretary, approved by the President and distributed by the office not later than 6 weeks after the meeting.

A.3. BUREAU

- A.3.1. The Bureau is composed of a President, three Vice Presidents, a Secretary and a Technical Secretary. It is completed by the immediate past President of the CIAM, who, however, does not have voting rights. The President may also invite the chairmen of the various subcommittees as well as representatives for the NAC's preparing world championships or other persons required for the business of the Bureau.
- A.3.2. The following matters are within the Bureau's competence:
- a) The interpretation, application and control of CIAM decisions;
 - b) The control of organisation of world championships;
 - c) The approval of world championships juries and judges;
 - d) The submission of proposals to the CIAM;
 - e) The accomplishment of any mission conferred to the Bureau by the CIAM.

It is not in the competence of the Bureau to alter decisions taken during the Plenary meeting regarding the maximum entry fee for competitors and helpers at World and Continental Championships.

- A.3.3. The Secretary shall keep a register of the CIAM perpetual trophies and be responsible for preparing the minutes of each meeting and sending them to the FAI office and the President within 4 weeks.
- A.3.4. An Assistant Secretary may be appointed by the Bureau of the CIAM for the purpose of preparing official translations of minutes and regulations.
- A.3.5. The Technical Secretary shall be responsible for maintaining the current Sporting Code Section 4 complete with amendments and additions in accordance with the decisions of the CIAM. He will also coordinate the work of the specialist subcommittees as necessary. The Technical Secretary will also check the record attempt dossiers.

A.3.6. The Bureau meets once a year in December and when convened by the President of the CIAM.

A.4. SUBCOMMITTEES

A.4.1. The CIAM may set up subcommittees, which are consulted by it for advice on sporting and technical matters in the special category concerned.

A.4.2. The CIAM elects by secret ballot the chairman of each technical subcommittee for a period of one year at a time. He should preferably, but not necessarily, be a delegate. He may be re-elected for an unlimited number of terms. He may not serve on more than one subcommittee.

A.4.3. Each subcommittee shall consist of a minimum of six members including the chairman, all of different nationality, regardless of the number of members. The Subcommittee chairmen shall on their own initiative invite the members, but they must be approved by their National Airsports Controls. The NAC's may suggest but not appoint alternative members.

A.4.4. The Subcommittee members serve as individual expert consultants and are not obliged to represent the views of their National Airsports Controls.

A.5 FORMS OF SUBCOMMITTEE WORK

A.5.1 The Subcommittee chairmen are free to organise the work of their Subcommittees, meetings, correspondence etc., as they consider most efficient. The chairmen must send a list of the members of their respective subcommittees as soon as they have been established to the CIAM President and the FAI office. The same procedure applies for any changes in the membership of the Subcommittees.

A.5.2. The Subcommittees may in no case publish recommendations, guides or rules, which have not been previously approved by the CIAM or the Bureau.

A.6. PROPOSAL SUBMITTED TO THE CIAM

A.6.1 Each proposal must conform to the following requirements:

- a) State the page number(s) in the Sporting Code, or its relevant approved amendments, on which the proposal will appear;
- b) Quote the relevant paragraph and/or heading from the Sporting Code;
- c) Detail exactly what the alteration or addition to the wording is to be;
- d) Give the reason(s) behind the proposed alteration in a short separate paragraph;
- e) Proposals must be submitted on a special form, designed for this purpose, available from the FAI Office. (See Annex A.2).
- f) Submit any and all proposals for each category of rules on forms separate from those for other categories, i.e. Free Flight proposals separate from Control Line, RC aerobatics separate from RC soaring, etc.

See also paragraph A.12

A.6.2. Proposals may be submitted to the CIAM by:

- a) All National Airsport Controls and/or NAC approved CIAM delegates.
- b) The Bureau of the CIAM;
- c) The chairmen of the Subcommittees subsequent to the agreement of the majority of the members of the Subcommittee concerned.

A.7. TIMETABLE FOR PROPOSALS TO THE CIAM PLENARY MEETING AND AGENDA FOR THIS MEETING

A.7.1. All proposals from the Subcommittees and from the NAC's for the Plenary Meeting must be received by the FAI Office by the 15th November in electronic form and hard copy in order to be included in the Agenda. The office will e-mail the proposals to the relevant Subcommittee Chairmen, who must present their findings in print at the Bureau Meeting. Proposals are to be approved at the Bureau meeting after which the Secretary sets up a draft of the Plenary Meeting Agenda to be approved by the President. The Office will finalise the Agenda and send it out to the NAC's according to A.1.3. See also A.12.

A.8. LANGUAGES

A.8.1. The working language of the CIAM is English.

A.9. CONTEST CALENDAR

A.9.1. Requests for contests to be put on the FAI International Contest Calendar must be received by the FAI Office no later than the 15 November, with the name, address, telephone, fax etc. of a contact person for additional information.

Open International contests may be requested for approval in between CIAM meetings, if submitted at least three months in advance to the FAI Office with copies to the CIAM President and Technical Secretary. Open International applications received by the FAI office later than November 15 will not be eligible for inclusion in a World Cup for the following year.

All applications for contests must be accompanied by a fee to CIAM. If the fee is not received by 15 November, the contest will be deleted from the calendar. The amount of this fee is determined annually by CIAM as defined in paragraph A.13.1.

Sanction fees for World and Continental Championships must be received at the FAI Account by November 15, and the documents concerning the event must arrive at the FAI office no later than November 15.

The form to be used is shown in Annex 2 of this section.

A.9.2. The Bureau has the right at any time to remove any contest from the CIAM Calendar if, in the opinion of the Bureau, the organisation would not appear to be up to the expected standard. The President will ensure that all National Airports Controls are informed.

A.10. JUDGES LISTS

Nominations for persons to be put on the List of International Judges must be received by the FAI Office no later than March 01 to be available at the Plenary meeting. The list is valid for the year starting the next January. The nomination must contain the addresses, telephone, fax and e-mail of the nominees.

The form to be used is shown in Annex 2 of this section.

A.11. LIST OF TECHNICAL EXPERTS

Nominations for persons to be put on the list of technical experts from which the elected subcommittee chairmen can choose their members, must be received by the FAI Office no later than March 01. The nomination form must contain the addresses, telephone, fax and e-mail of the nominees. The Subcommittees' terms of office will be between Plenary Meetings.

The form to be used is shown in Annex 2 of this section.

A.12. EFFECTIVE DATE OF RULE CHANGES

In all classes, the four year rule for no changes to model aircraft / space model specifications, manoeuvre schedules and competition rules will be strictly enforced, but in step with the World Championship cycle of each category. The classes with World Championships in even years will use 2000 as a starting point: the rules decided on in 2000 will be in force in 01, 02, 03, and 04. Any amendments decided on in 04 will be implemented starting in 05, a year before the World Championships in 06, and remain in effect 06, 07, 08, after which a new four year cycle begins. For classes with World Championships in odd years 2001 will be the starting point. The rules may then be amended the next time in 05, to come into effect 06, the year before the following World Championship, and so on.

All proposals are first to be carefully scrutinised by the Chairmen of the relevant subcommittees who will check them for validity before presenting them to the Bureau. It will be the Chairman's duty to point out any ambiguities or lack of conformity with CIAM requirements in the proposal, as well as any effects it may have on other regulations.

All technical amendments must be accompanied by supporting data. Amendments to rule changes not yet implemented will not be accepted.

The only exceptions allowed to the four year rule freeze are genuine and urgent safety matters, indispensable rule clarifications and noise rulings.

All rule proposals, guides and whatever items accepted for the agenda must also be made available in electronic form to facilitate compilation of the Agenda.

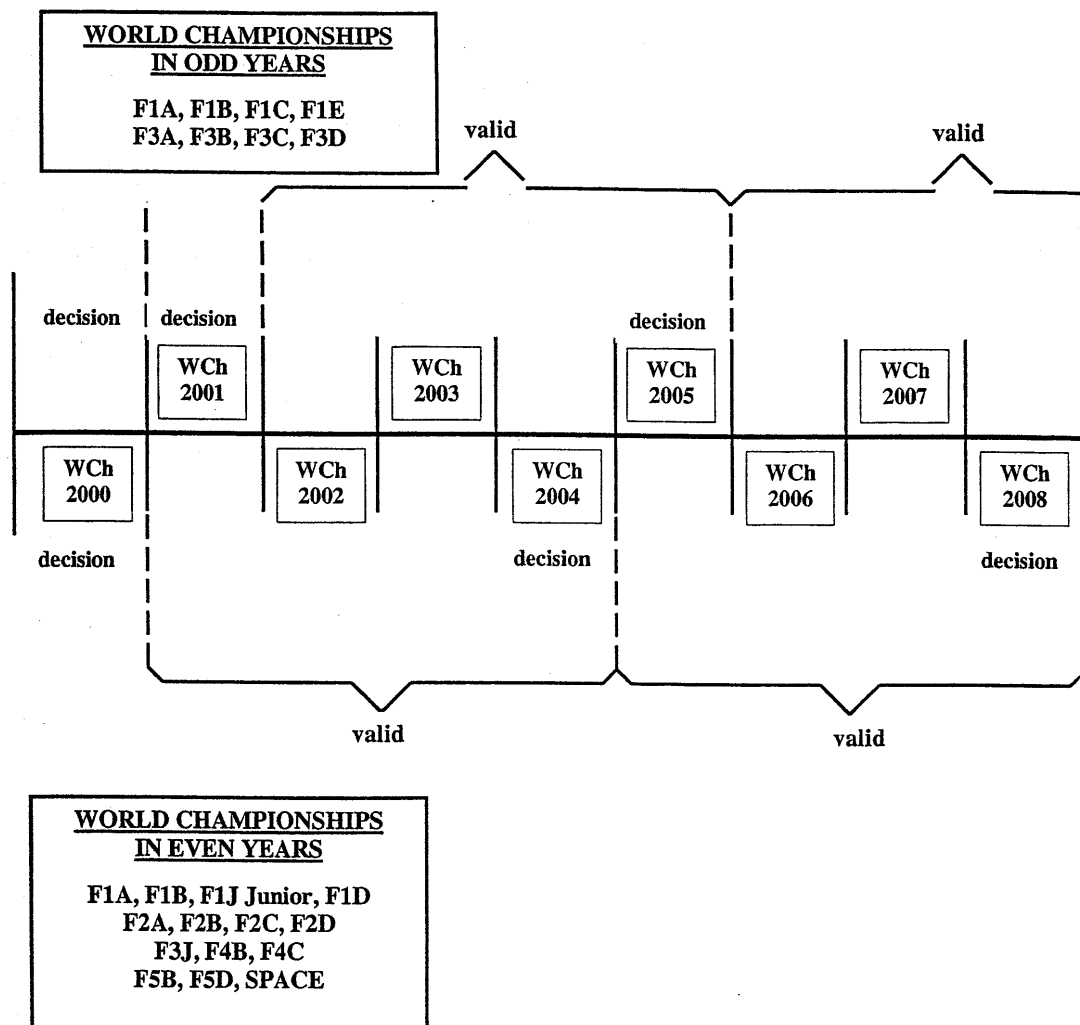

The Technical Secretary will after the Plenary Meeting prepare a list of amendments, which will be effective on the 1st January of next year, to be approved by the President and distributed by the FAI office to NAC's and Bureau officers with the Minutes.

A.13. AEROMODELLING FUND

A.13.1. An Aeromodelling Fund shall be maintained to hold monies paid as sanction fees for listing events in the FAI Sporting Calendar. These fees for all contests on the CIAM FAI contest calendar shall be reviewed each year by the Bureau and the fee changes proposed by the Bureau must be approved by the Plenary Meeting.

A.13.2. The fund shall be used for:

- paying of unrecouped costs of publishing the CIAM Flyer;
- paying the cost of FAI Medals and Diplomas for Model Aircraft and Space-modelling World Cup events;
- paying the refurbishment of World Championship Trophies when required;
- re-imbusement of the fare and accommodation costs incurred by the CIAM President or his alternate in attending the FAI General Conference, the CIAM Bureau and Plenary Meetings and;
- paying the costs, to the limit of available funds in any year, not properly a charge on a NAC, of attendance at Bureau Meetings.

A.14. CHANGE FROM PROVISIONAL TO OFFICIAL RULES

- A.14.1. Before being considered for adoption by the CIAM as official FAI rules, provisional rules must first have been used in at least five international contests, involving a total of at least five FAI member countries (but not necessarily five countries per contest).

A.15. ELIGIBILITY FOR WORLD CHAMPIONSHIPS

- A.15.1. Before they can be considered by the CIAM for use in world championships, there must be a minimum period of two years from the time the rules were made official during which at least two international contests were held, each with a minimum of five FAI member nations participating. Also, reports from the chairman of the jury in each contest must be sent to the appropriate subcommittee chairman for the latter's recommendation to the CIAM.

ANNEX A.1

GUIDE FOR SUBMITTING WORLD AND CONTINENTAL CHAMPIONSHIP PROPOSALS TO CIAM FOR APPROVAL

DATES: List opening and closing dates and registration date.

LOCATION: Describe the area and enclose a map showing the housing and the flying field.

JURY AND JUDGES: List the FAI Jury president and members for approval at the Bureau or Plenary Meeting. See rules for composition of jury. Select judges from CIAM approved list.

EVENTS: List events by number and description. Show schedule of time and date for each event.

TEAMS: State total number of competitors allowed from each country and any additional personnel such as team manager, helpers, interpreters that would make up the official team approved by the NAC.

AWARDS: State what prizes will be awarded - medals, trophies, certificates, including for what places and events they will be given. FAI awards are only awarded at World Championships and as a final reward of a World Cup cycle.

LAUNCH/FLYING SITE: Outline launching or other equipment, competitor team area, tents, first aid and other facilities available at the flying site, including refreshment and toilet facilities.

ACCOMMODATION AND CATERING: Include description of housing, meal facilities and banquet.

TRANSPORTATION: Indicate what transportation will be provided by the organiser and what transportation is required by the competitors. Also describe methods of arrival at the housing area.

TOUR: One day must be set aside as a free day near the end of the competition to allow for completion of flying if the schedule is delayed by weather or other factors. It is of primary importance to complete the flying schedule. If other activities are scheduled on that day, such as the organisers providing a special tour of interest, then this is secondary to the completion of the championships. If a tour is included in the entry package, then this must be an option and its fee must be separate from the main entry. Tourist information may be supplied to assist competitors' stay in the area.

ENTRY FEES: The entry fee will consist of an obligatory fee to be paid by all competitors and team managers and an optional fee that covers accommodation and food. All costs must be stated in CHF (Swiss Francs). Outline what the fee includes (Competition entry fee, meals, housing, transportation, etc.) for competitors, helpers and supporters.

CORRESPONDENCE: List name, addresses, telephone, fax and e-mail of the person responsible, to whom all correspondence concerning the championship should be addressed.

PRECEDENTS: Include details of international competitions for the relevant categories, which have taken, place at the same location and with a similar organization; if any.

BUDGET: Present a budget for the total cost of the event to enable CIAM to confirm that the entry fees and accommodation and meal charges have been set at a reasonable level. Supporting information to the budget must include authenticated evidence of local costs of accommodation and meals and a statement of the currency exchange rate assumed in the budget.

FEDERATION AERONAUTIQUE INTERNATIONALE

Registration of Competitions in the FAI Aeromodelling Sporting Calendar

This form must be received by the Head Office by November 15 in order that the subject event may be included in the first issue of next year's FAI-CIAM Contest Calendar.

From :

National Airsport Control (NAC)

Address :

Street

City

Country

Official stamp of NAC

To : FEDERATION AERONAUTIQUE INTERNATIONALE
Avenue Mon Repos 24
CH - 1005 LAUSANNE (Switzerland)

Date : _____

The Aero Club of _____ wishes to have the following Competition listed in the FAI Aeromodelling Sporting Calendar for the year (Use only one form for each competition ; additional forms may be obtained from the FAI Office) (or duplicate this form precisely).

Attention is called to Article B.2 of Section 4 of the Sporting Code defining the type of international events.

Provide the following information :

1. Type of Event Open International - World Cup
 Open International - Non World Cup
 Limited International
 Continental Championships
 World Championships
 2. Title of Event
 3. Class of Model(s) (e.g. F1A, F3B, F4C, etc.)
 4. Date of Event
 5. Alternate Date (in the event of a clash of dates)
 6. Location (City) Country
 7. Entry Fee CHF
 8. Organizer
- Address of Contact Person :
.....
.....
- Phone :
Fax :

This request must be accompanied by a Sanction Fee. With effect the year 2000, the fee for single line listing of events in the Sporting Calendar will be :

World Championships	- 400 SF
Continental Championships	- 250 SF
Open Internationals	- 125 SF

Fees to be paid to :

FAI Account n° 0425-457968-31

Swift Code : CRES CHZZ 10A

Credit Suisse Private Banking

Rue du Lion d'Or 5-7, Case postale 2468

CH-1002 Lausanne (Switzerland)

Signature of NAC Authority

FEDERATION AERONAUTIQUE INTERNATIONALE
NOMINATION FOR AEROMODELLING INTERNATIONAL
FAI JUDGES

From _____ :

NAC

Address :

Street

City

Country

To :

FEDERATION AERONAUTIQUE INTERNATIONALE
Avenue Mon Repos 24
1005 Lausanne
Switzerland

(must arrive at FAI Office by March 01 at the latest)

The National Airport Control of _____ wishes to nominate the persons listed on the other side of this form as international FAI Judges for each of the following categories of aeromodelling. Only five nominations are allowed in each category. Qualifications must be given in all cases.

Official stamp of NAC

Signature of NAC Authority

Date

NOMINATION FORM FOR AEROMODELLING INTERNATIONAL FAI JUDGES

CAT.	NOMINEE(S) NAME(S) & ADDRESS(ES)	QUALIFICATIONS
F2B	1. 2. 3. 4. 5.	
F2C	1. 2. 3. 4. 5.	
F2D	1. 2. 3. 4. 5.	
F3A/F5A	1. 2. 3. 4. 5.	
F3C	1. 2. 3. 4. 5.	
F4B	1. 2. 3. 4. 5.	
F4C	1. 2. 3. 4. 5.	
S7	1. 2. 3. 4. 5.	

Signature of NAC Authority

FEDERATION AERONAUTIQUE INTERNATIONALE
NOMINATION OF CANDIDATES FOR AEROMODELLING
TECHNICAL SUB-COMMITTEES

From _____ :

NAC

Address :

Street

City

Country

To FEDERATION AERONAUTIQUE INTERNATIONALE

Avenue Mon Repos 24

1005 Lausanne

Switzerland

(must arrive at FAI Office by March 01 at the latest)

The National Airsport Control of _____ wishes to
nominate the persons listed on the other side of this form for consideration by the elected Chairman of Technical
Sub-Committees as technical experts in the following categories of aeromodelling.

Official stamp of NAC

Signature of NAC Authority

Date

FORM FOR NOMINATION OF CANDIDATES FOR AEROMODELLING TECHNICAL SUB-COMMITTEES

CAT.	NOMINEE(S) NAME(S) & ADDRESS(ES)	QUALIFICATIONS
F1		
F2		
F3A		
F3B		
F3C		
F3D		
F5		
F4		
S7		
<u>Education and Information</u>		

Signature of NAC Authority

FAI AEROMODELLING COMMISSION - NOMINATION OF OFFICE HOLDERS FOR 2001/2002

Please indicate below the names of any persons you wish to nominate for the posts shown. Only DELEGATES are entitled to make nominations. PLEASE DO NOT SIGN THE FORM. This is a secret procedure.

Candidates for the posts of PRESIDENT and VICE PRESIDENTS must be approved Delegates to the FAI Aeromodelling Commission, or already hold the post of President. (FAI By-Laws 5.4.4 and 5.4.8).

It is usual, but not mandatory, for the Presidents of Sub-Committees to be Delegates (By-Law 5.7.1).

OFFICERS :

CIAM PRESIDENT

1st VICE PRESIDENT

2nd VICE PRESIDENT

3rd VICE PRESIDENT

SECRETARY

TECHNICAL SECRETARY

**FRENCH-SPEAKING
SECRETARY**

SUB-COMMITTEE CHAIRMEN :

FREE FLIGHT

CONTROL LINE

F3A

F3B & F3J

F3C

F3D

SCALE

ELECTRIC

SPACE

INFO/EDUCATION

FEDERATION AERONAUTIQUE INTERNATIONALE
FAI AEROMODELLING COMMISSION (CIAM)

Date :

Proposal submitted by :

Sporting Code					Supplemental to the Sporting Code		
Section	Part	Class	Paragraph	Page	Subject	Page	Provisional Rule

Proposed alteration or addition :

Reason(s) :

Annex(es) :

FEDERATION AERONAUTIQUE INTERNATIONALE

NOMINATION FORM

THE ANTONOV DIPLOMA

(for technical innovation(s))

From NAC : _____

Date : _____

Address : _____

Country : _____

(only one person from a country may be
nominated annually by that candidate's
National Airsport Control)

Name of Nominee : _____

Address : _____

DESCRIPTION OF TECHNICAL INNOVATION(S) - Please Print

.....
.....
.....
.....
.....
.....
.....
.....
.....
.....
.....

NAC Signature .. _____

President or Secretary General of nominating FAI National Airsport Control

(must be submitted to the FAI Office by November 15)

FEDERATION AERONAUTIQUE INTERNATIONALE

NOMINATION FORM

THE ANDREI TUPOLEV MEDAL

(for World and National Championship victories in the same class on the same year)

From NAC : _____

Date : _____

Address : _____

Country : _____

(only one person from a country may be nominated annually by that candidate's National Airsport Control)

Name of Nominee : _____

Address : _____

REQUIREMENTS - Please Print

World Championship during which the World Champion title was obtained :

Championship name:

Championship dates : Championship place:

Class of Model in which the modeller competed :

National Championship during which the National Champion title was obtained :

Championship name:

Championship dates : Championship place:

Class of Model in which the modeller competed :

NAC Signature .. _____

President or Secretary General of nominating FAI National Airsport Control

(must be submitted to the FAI Office by November 15)

FEDERATION AERONAUTIQUE INTERNATIONALE

NOMINATION FORM

THE ANDREI TUPOLEV DIPLOMA

(for outstanding record performance)

From NAC : _____

Date : _____

Address : _____

Country : _____

(only one person from a country may be
nominated annually by that candidate's
National Airsport Control)

Name of Nominee : _____

Address : _____

DESCRIPTION OF OUTSTANDING RECORD PERFORMANCE IN AEROMODELLING - Please Print

.....
.....
.....
.....
.....
.....
.....
.....
.....
.....
.....
.....

NAC Signature .. _____

President or Secretary General of nominating FAI National Airsport Control

(must be submitted to the FAI Office by November 15)

FEDERATION AERONAUTIQUE INTERNATIONALE

NOMINATION FORM

ALPHONSE PENAUD DIPLOMA

(for sporting achievements)

From NAC : _____ Date : _____

Address : _____ Country : _____

(only one person from a country may be nominated annually by that candidate's National Airsport Control)

Name of Nominee : _____

Address : _____

Requirements - one who has had either :

1. at least three times consecutively the title of National Champion :

dates : _____

2. at least the title of World Champion :

date : _____ WC :

3. at least three world records :

dates : _____

category : _____

4. other outstanding sporting achievements :

description : (please print)

.....
.....
.....
.....
.....
.....
.....

NAC Signature .. _____

President or Secretary General of nominating FAI National Airsport Control

(must be submitted to the FAI Office by November 15)

FEDERATION AERONAUTIQUE INTERNATIONALE

NOMINATION FORM
FAI AEROMODELLING GOLD MEDAL
(for outstanding merit in organisational activities)

From NAC : _____ Date : _____

Address : _____ Country : _____

(only one person from a country may be nominated annually by that candidate's National Airsport Control)

Name of Nominee : _____

Address : _____

Requirements - one who has been either :

- 1. [] at least twice Competition Director or similar function at WC or European Championships :

dates : _____

locations : _____

- 2. [] at least 3 times FAI jury member at World or European Championships :

dates : _____

locations : _____

- 3. [] at least 5 times judge or similar function at World or Continental Championships :

dates : _____ locations : _____

- 4. [] at least 3 years NAC delegate to FAI Aeromodelling Commission (CIAM) or another function within CIAM :

dates : _____

- 5. [] shown outstanding merits in developing aeromodelling by organisational activities :

description : (please print)

.....

.....

.....

NAC Signature _____

President or Secretary General of nominating FAI National Airsport Control

(must be submitted to the FAI Office by November 15)

FEDERATION AERONAUTIQUE INTERNATIONALE

NOMINATION FORM

THE FRANK EHLING DIPLOMA

(for outstanding accomplishment, by an organisation or individual, in connection with the promotion of aviation through the use of flying models)

From NAC : _____

Date : _____

Address : _____

Country : _____

(only one person from a country may be nominated annually by that candidate's National Airsport Control)

Name of Nominee : _____

Address : _____

FULL INFORMATION ABOUT THE CANDIDATE'S ACTIVITIES UP TO 31st DECEMBER OF THE PRECEDING YEAR - Please Print

.....
.....
.....
.....
.....
.....
.....
.....
.....
.....
.....

NAC Signature .. _____

President or Secretary General of nominating FAI National Airsport Control

(must be submitted to the FAI Office by November 15)

SECTION 4B

GENERAL RULES FOR INTERNATIONAL CONTESTS

B.1. GENERAL DEFINITION OF INTERNATIONAL CONTESTS

Any model aircraft and spacemodelling event in which the competitors are persons or teams from at least two different nations. Organised by the NAC or with its permission or participation under the rules of the Sporting Code Section 4b, c and d, these contests must be entered in the FAI Contest Calendar and are open only to persons holding a valid Sporting Licence of the FAI.

B.2. TYPES OF INTERNATIONAL CONTESTS

B.2.1. Open International Contests

Contests in which all competitors who possess an FAI Sporting Licence may enter. These contests are for individual classification only.

B.2.2. Limited International Contests

Contests in which all competitors are nominated by their NAC. These contests are for individual and possibly international team classification.

B.2.3. Continental Championships

These are limited international contests in which the competitors are nominated by their NAC and are persons or teams from at least four different nations from one continent. These contests are for individual and possibly team classification and will be organised only in the years when there is no world championship in the particular class.

B.2.4. World Championships

These are limited international contest in which the competitors must be nominated by their NAC and are persons or teams from at least five different nations. If the entry is less than five different nations, the world championships must be cancelled. These contests are for individual and national team classification.

The world championships shall be planned and scheduled by the CIAM.

Each world championships are normally held every other year.

B.2.5. World Cup

This is a classification of the results of special open international contests during a year. A world cup may be organised by the relevant CIAM Subcommittee for any of the classes recognised as world championships.

If a CIAM Subcommittee chooses to run a World Cup, it must:

- a) define rules and points allocation; these must be published in the Sporting Code;
- b) nominate in advance the open international contests which are to be included from the FAI Contest Calendar;
- c) collect results from each competition and allocate points to competitors;
- d) produce and distribute current positions in the World Cup during the year.
- e) in each category, award a medal and diploma from the FAI to the winner and a diploma from the FAI to the second and third places.

B.2.6. International Ranking

This is a continuous classification based on the results of all open and international events, as well as Continental and World championships and world cup contest. An international ranking may be organised by the relevant CIAM subcommittee for any of the classes recognised as world championships.

If a CIAM Subcommittee chooses to run an international ranking, it must:

- a) define rules and ranking algorithm, these must be published in the Sporting Code.
- b) Collect results from each competition and apply the ranking algorithm on them.
- c) Produce and distribute up-dated ranking lists during the year

B.3. COMPETITORS AND TEAMS

B.3.1. Competitor

Unless stated otherwise, the competitor named on the entry form must be builder of the model aircraft entered.

B.3.2. Sporting Licences

Every competitor, team manager and assistant team manager entering an international contest must possess a valid Sporting Licence of the FAI. This Sporting Licence is issued by the NAC of the competitor, team manager or assistant team manager under the conditions of the General Section of the Sporting Code and must bear the national identification mark.

B.3.3. Competitor's Proxy and Substitution of Team Members

Proxy flights are not permitted in any class or category of either model aircraft and space models. Substitution of team members is permitted only up to the time of registration or prior to model processing, whichever comes first.

B.3.4. Age Classification for the Contest

A competitor is considered to be a junior up to and including the calendar year in which he attains the age of 18. All other competitors are classed as Seniors.

- a) World or Continental Championships may be organised specifically for juniors. At these Junior Championships, all competitors and all helpers, team members, mechanics and assistants must all be juniors. Except at RC Soaring (F3B and F3J) Championships, the team managers and/or their duly registered assistants and organising officials are the only seniors allowed in the starting area.
- b) If there are three or more junior entries in an Open International, there must be a separate junior classification included in the results.

B.3.5. National Teams for World and Continental Championships

A national team shall consist of three individual competitors, or three pairs of competitors for each category as a maximum, and a Team Manager. For control line (F2) only, the team may consist of four individual competitors or four pairs of competitors for each category as a maximum provided that the fourth competitor is/are junior(s), plus a team manager. The reigning World or Continental Champion has the right (subject to the approval of his National Airsports Control) to participate in the next world or continental championships in that category regardless of whether he qualifies for the national team or not. If he is not a member of the national team, his score will not be considered in the team results.

B.3.6. Team Manager

The team manager may assist the competitors. He is the only person allowed to deal with the Jury or the Organiser in the case of disputes, complaints or protests.

For Free Flight, Control Line, Scale and Space Model competitions, the team manager may have an assistant, registered with the organiser, who will have the same duties as the team manager except that the assistant will not be allowed to deal with the Jury or the Organiser except to deliver protests.

B.4. CONTEST OFFICIALS

B.4.1 FAI Jury

The Organiser of all International contests included in the FAI Contest Calendar shall nominate an FAI Jury of three members at least two of whom shall be chosen for their competence in the category being flown in the event. It is the responsibility of the Jury to see that the event is conducted in accordance with the relevant provisions of the Sporting Code Section 4b, c and d, and they are empowered to make all decisions dictated by any circumstances which may arise and to rule on disputes. Before the start of the competition, the FAI Jury must make sure that the organiser has satisfied the requirements of B.7.

The FAI Jury must have at least one language in common.

The FAI Jury at World and Continental championships shall remain independent of the organiser(s) to enable them to enforce the rules of the FAI and act as an independent arbiter in disputes between the organiser(s) and the competitors.

The President of the Jury at each international contest must submit a report to the FAI within one month of the contest. This report must include descriptions of any deviation from the Sporting Code and any exceptional circumstances that arose.

B.4.2. In the case of world championships, the Jury must include at least one member of the CIAM Bureau or the Chairman of the CIAM particular Subcommittee. The second member must be a CIAM delegate or either someone who in the past 5 years has served on a FAI world championships Jury, or in the past 5 years has served two consecutive years on a Subcommittee in the same category as the world championships. The remaining member can be delegated by the NAC of the organising country provided that if the choice is made from another country approval will first have been obtained from that Jury member's NAC. The members of a W.Ch. or C.Ch. Jury shall be of different nationalities. All W.Ch. and C.Ch. Juries must be approved by the CIAM Bureau. The members of an international Jury must have recent practical judging and/or flying experience of the relevant category.

B.4.3. In the case of continental championships, the Jury must include at least one CIAM delegate. The three members of a C.Ch. Jury shall be of different nationalities and have the approval of their NAC's.

B.4.4. In the case of other international events, the Jury must include at least one CIAM delegate or a person approved by his/her NAC. The other two members can be delegated by the NAC of the organising country. Members of the Jury must be from at least two different nations.

The Jury must be announced before the start of the event. Members of the Jury may not compete in the event except when the timetable gives a sub-division into categories. In that case, one or two members of the Jury may compete in a category and must then be replaced by alternate Jury members (not competing in that category) for all matters involving that category. The alternate members must be chosen so that at all times the Jury meets nationality and language rules.

B.4.5. Contest Officials

The organisers may appoint timekeepers and other contest officials from other countries provided those are approved by their own NAC.

B.4.6. The NAC responsible for organising a W.Ch. or C.Ch. shall submit to the CIAM or CIAM Bureau the names of the persons who shall act as judges for approval. International judges must have had recent practical judging and/or flying experience of the category for which they are selected.

B.4.7. The organiser of a CIAM competition must bear the expenses of CIAM Bureau designated jurors and judges for accommodation and meals in the course of the competition, and all transportation costs to and from the competition site (air fare economy class). This does not apply to any Jury members who compete in the competition under the terms of B.4.4.

B.5. ORGANISATION OF INTERNATIONAL CONTESTS

B.5.1. Each International Contest in the FAI Contest Calendar must be organised in accordance with the Sporting Code General Section and Sections 4b and 4c (or 4b and 4d.)

The advice of appropriate CIAM Organisers' Guides must be followed.

The rules must be displayed at the contest ground in English and in the language of the organizing country.

B.5.2. World and Continental Championships Events

The CIAM will decide which event shall be held as a World Championship and Continental Championship and to which NAC shall be delegated the responsibility for the organisation of this event. Bids to host Championships may be submitted at any time in advance of a chosen year. The firm acceptance of a bid will normally be made by vote of the CIAM Plenary meeting two years in advance of the year of the proposed championships. In exceptional circumstances, the decision for awarding World and Continental Championships may be taken more than two years in advance of the year of the proposed championships, providing a request is made by November 15 and published in the Agenda of the following Plenary Meeting. In order to be eligible for selection, all bids must include the full details in the Guide at Annex 1 to Section 4a. In the event that no acceptable bid is available two years in advance, the decision may be postponed to the Plenary meeting in the year before the championship. If no bid is accepted at that meeting, the Plenary Meeting may exceptionally delegate the decision to the CIAM Bureau meeting at the end of that year. This is the latest time at which the decision can be made to proceed with a championship for the following year.

B.5.3. Local Rules

Local rules established by the organizers must be published no later than the latest bulletin made available to all competitors, preferably in advance of entry deadline. Local rules decided later must be issued in writing prior to the start of the contest.

B.6. CONTEST INFORMATION AND ENTRY FEES

B.6.1. A first memorandum of information and entry forms must be despatched to the NAC's, also to Jury members and judges at least three months before the contest. For open international contests, entry forms supplied by the organisers must include:

Name - First name - Date of Birth - Postal address - Nationality - FAI Licence - Class(es) entered.

B.6.2. The entry fee will consist of an obligatory fee to be paid by all competitors and team managers and an optional fee that covers accommodation and food. If an obligatory fee is required for official helpers and official supporters it must not exceed 20% of the obligatory fee for competitors. Accredited representatives of the media shall not be required to pay an entry fee. Items contributing to the calculation of the Basic Entry Fee are (applicable depending on local circumstances): Contest site - rent and cost for preparing, and organisational costs. Organisational costs consist of meetings/travel of organising committee; rent or purchase of contest equipment if not already available, such as timing devices, lap counters, sighting apparatus, processing equipment, score board, walkie-talkies, frequency control equipment, score sheets, flags, flag poles, etc., cost of instruction and briefing session of contest officials and Jury, licences and permits (PTT, local authorities); stationary, postage (information bulletins, correspondence); rent of tents. The cost of any Official opening ceremony must be included in the items to be taken into account when calculating the basic entry fee.

B.6.3. It might be possible to obtain a sponsor for one or more of the above items. This will result in a lower basic fee, therefore sponsoring is highly recommended. However, sponsoring can only be taken into account if it is absolutely sure that it will be obtained, otherwise a loss can be expected. Sponsoring negotiations should start as early as practical.

B.6.4. Separate additional fees will be offered at choice for: lodging hotel and camping; food (banquet not included) and banquet (and possible other additional events). Maximum fee = basic fee + lodging (hotel) + food + banquet.

The maximum possible fee is CHF 900 for seven nights, except for events which require a large number of judges or more than seven nights.

The cost of hotel accommodation must be kept reasonable. Keep in mind that hotel accommodation is often the only possibility for overseas participants. Accommodation of acceptable middle class standard will be sufficient. There is no need for any luxury. The same applies to the food.

For World championship events that require more than five international judges, a separate additional fee may be charged to each contestant to cover the actual cost of travel, lodging and meals for those judges in excess of five. The additional fee is limited to a maximum of CHF 245.00 per contestant.

B.6.5. Results must be despatched to the FAI and NACs taking part in the event within a month. For events included in a World Cup, the results must be despatched to the relevant World Cup organiser within a month. The results must include the full name and nationality of those listed and for Scale events must also include the name of the prototype

air- or spacecraft subject flown by the competitor.

B.6.6. The organiser must acknowledge receipt of the entry form and entry fee.

B.7. SPECIAL CONTEST ORGANISATION REQUIREMENTS

The organisers must:

B.7.1. Secure a sufficient number of qualified officials, timekeepers and FAI Jury members.

B.7.2. Provide themselves with the necessary measuring apparatus adequate to check the characteristics of model aircraft or spacemodels in question.. A list of minimum measuring apparatus is given in the Organisers' Guide for each class.

B.7.3. Give the competitors opportunity to determine the characteristics of their models on the official measuring equipment before the contest.

B.7.4. Provide at least one practice day prior to the competition, to be announced in the invitation along with a flying schedule for the competition. For Free Flight models, the flying schedule is F1A, F1B and F1C.

The organiser will provide a schedule for the official practice giving all competitors equal practice time. The practice day must not be extended so as to delay the start of official competition. A reserve day must be scheduled after the competition to allow for the completion of official flying in the event of weather or other delays preventing completion as scheduled.

B.7.5. The organiser must also provide the name and address of a contact person, who will be able to inform foreign teams.

B.7.6. Display the results of each round throughout the contest and publish the official results afterwards. The display and publication shall not contain any additional statistics or items other than those required by the Sporting Code. Abbreviations to indicate nationality must follow the list given in Annex 2.

B.7.7. In Free Flight events, provide each starting position with two timekeepers in championships or with at least one timekeeper for other contests. For flyoffs an additional timekeeper must be provided (i.e. three for championships, at least two for other contests). All timekeepers must have binoculars.

Each starting position must be equipped with at least one tripod for supporting binoculars.

B.7.8. Establish a suitable contest area allowing the full performance of the model aircraft and safe recovery.

B.7.9. Organisers of World and Continental Championships and of Open International events on the CIAM Contest Calendar must provide the same third party insurance cover to foreign participants that their own members enjoy domestically.

B.7.10. All timekeeping shall be made with quartz-controlled electronic stopwatches with digital readout.

B.8. RADIO CONTROL

B.8.1. Each day, before the start of competition, all transmitters on the competition site to be used in the contest for that day must be impounded and kept under supervision of a special official. This official will issue the transmitter to the competitor only when he is called to make his flight (in accordance with the procedure laid down for the class concerned). Flight line officials must watch the competitor(s) to prevent him (them) from switching on the transmitter(s) before the flight line director has given permission to do so.

The transmitter frequency must be displayed on the outside of the transmitter or plug-in module or frequency switch. Also, frequency synthesised transmitters must be designed to display the current frequency and to change to another frequency without RF transmission.

Unless otherwise stated in the rules for a particular class the competitor is allowed only one frequency for the contest.

Note: In the case of proven interference another single frequency may be allocated by the contest director.

B.8.2. As soon as the flight has ended, the competitor must immediately return his transmitter to the impound official. Any unauthorised transmissions during the period of the contest will result in automatic disqualification of the offender from the entire contest and render him liable to further penalties.

- B.8.3. The organiser must provide a spectrum analyser or other adequate radio monitoring equipment for the purpose of detecting radio interference and a means of communicating this information to the pilot(s) and/or flight line director.

Unless otherwise specified, the initial starting order of the various competitors must be established by means of a random draw before the contest, taking into account that frequency will not follow frequency except in F3B and F3J, team members will not be included in the same race in a heat of F3D or F5D nor will team member follow team member of the same team except in F3B and F3J.

- B.8.4. The organiser must survey the site of any competition where a radio controlled event is scheduled to be held in order to determine possible cases of radio interference which would affect any competitors. Any such possibilities must be reported as early as practical to participating National Airsports Controls. Frequency bands or specific frequencies which have been shown to be reasonably free from interference at the site of the competition will also be reported to the National Airsports Controls.

Organisers must make surveys of the competition site during both weekdays and weekends to determine if any patterns of radio interference exist and notify the National Airsports Controls of any further problems - many commercial or industrial operations are weekday problems only. In any case, it is the organiser's responsibility to make certain that all competitors in a radio controlled event are notified in advance about any known radio interference problems that may exist at the flying site and at what frequency.

B.9. TIMING

Note: This paragraph applies to Free Flight and Space Models only.

- B.9.1. Each team shall have the right to provide a timekeeper for the following classes of world and continental championships: F1A, F1B, F1C, F1D, F1E, S3, S4, S6, S8, S9, S10; with the organiser to be responsible for providing lodging and food only. Teams must nominate only skilled timekeepers and the timekeepers must bring binoculars, watches and tripods for their own use. The organiser must use these provided timekeepers as a priority, before allocating duties to national or other timekeepers.

Competitors can act as timekeepers.

- B.9.2. The timekeepers must familiarise themselves with the colour and shape of the model in order to recognise it during the flight.

- B.9.3. The flight is considered ended when the model touches the surface of the earth, encounters an obstacle which definitely terminates its flight or when it definitely disappears from the timekeeper's sight. If the model disappears behind some obstacle or in clouds, the timekeepers are to wait for 10 seconds; should the model not reappear, timing will cease and the 10 seconds will be subtracted from the flight time.

- B.9.4. The flights must be timed by two timekeepers during the first seven rounds and, in the fly-off, each flight must be timed by at least three timekeepers - the additional timekeepers preferably to be picked among the competitors - with quartz controlled electronic stopwatches with digital readout recording to at least 1/100th of a second.

All timekeepers must be equipped with binoculars.

- B.9.5. The timekeepers must remain within a circle of 10 metres radius during the flights and time the flights independently of each other.

- B.9.6. The time recorded is the mean of the times registered by the timekeepers, but reduced to the nearest whole number of seconds below the resulting mean time unless the difference between the times registered shows evidence of an error in the timing, in which case the organiser will determine, with the FAI Jury, which time will be registered as the official time or what other action should be taken.

- B.9.7. Instructions for using binoculars at F/F Contests:

- a) The binoculars must have a magnification of at least 7. On each starting position at least one of the binoculars will be mounted on a tripod.
- b) The timekeeper will adjust the binoculars before timing, so as to suit his eyesight. To do this the focus will first be adjusted with the centre knob, and then by separate adjustment of the adjustable eyepiece. The distance between the eyepieces will be adjusted so as to give a circular field of view.

Note: Binoculars with no central focusing device will be adjusted by altering each eyepiece in turn.

- c) After adjustment, any scale readings will be noted. This should simplify readjustment if needed.

- d) The timekeepers must not use the binoculars whilst the model is being launched. Use of the binoculars is suggested after about one minute of flight, except that in class F1A binoculars should be used whilst the model is being launched with the aim of clearly fixing the moment of its release in case the competitor has gone far away from the starting point.
- e) Use of the binoculars must not be left until too late in the flight, when there is a risk of not finding the model with the binoculars.

B.10. DURATION OF CONTEST

- B.10.1. Outdoor contests, including fly-off starts, must take place between the hours of sunrise and sunset, except classes F1A, F1B, F1C, also Spacemodels Duration; in these classes a minimum of two rounds must take place when wind and thermal activity are expected to be at a minimum. The contests may start earlier than sunrise if the distance covered by the models in relation to the size of the airfield suggests an interruption of the contest during the windiest part of the day. Such an interruption can be included in the contest programme or decided by the organisers with the approval of the Jury.
- B.10.2. The contest programme including round durations, and starting and finishing times of the contest must be clearly indicated in the regulations.

B.11. INTERRUPTION OF THE CONTEST

- B.11.1. The contest may be interrupted or the start delayed by the Jury if:
 - a) The wind is continuously stronger than 12 m/s (9 m/s for Free Flight, Scale and Space Models) measured at two metres above the ground at the starting line (flight line) for at least one minute (20 seconds for Free Flight), unless specified otherwise in category rules.
 - b) The visibility prohibits proper observation of the models (especially in case of F/F or R/C contest) or due to atmospheric conditions it would be dangerous to continue the competition.
 - c) It is necessary to reposition the starting line. This may only take place between rounds, or groups in F3B and F3J.
 - d) The prevailing conditions are such that they may lead to unacceptable sporting results.
 - e) For F3A, F5A, F3C and F4C contests the sun is in the manoeuvring area.

In the event of an interruption during a round, the remainder of the round may be completed as soon as conditions allow, with adequate notice given to all competitors and Team Managers.

- B.11.2. In the cases described, the organiser is not obliged to return the entry fee nor repeat the contest. The results will be based on the scores of the finished rounds.
- B.11.3. An interrupted contest can be extended if the requirements of article B.10.1. are met.

B.12. CLASSIFICATION AND AWARDS AT WORLD AND CONTINENTAL CHAMPIONSHIPS

B.12.1. Individual classification

- a) In each contest category an FAI medal and diploma will be awarded to the competitors in the first, second and third places.
- b) If there is a Challenge Trophy, this is awarded to the NAC of the winning competitor for custody until the following championship.
- c) The winner earns the title of World Champion in the category.
- d) For control line where a junior may participate in a Continental or World Championship National Team individual awards for junior competitor will be awarded to the first, second and third place juniors. Where at least four juniors from at least four different nations participate, the winner shall earn the title of Junior Continental Champion in the category. Where at least five juniors from five nations participate in a World Championship, the winner shall earn the title of Junior World Champion in the category.
- e) The cost for the individual medals will be borne by the organiser of the Championships

B.12.2. International Team Classification

- a) The international team classification is established by adding the scores of the three team members of the team together (in the case of F2A, F2B, F2D the three best scoring members or in the case of F2C the three best scoring teams). In the case of a team tie, the team with the lower sum of place numbers, given in order from the top, wins. If still equal, the best individual placing decides.
- b) In each class an FAI medal will be awarded to the team manager of the first, second and third winning teams.
- c) In each class a diploma will be awarded by the FAI to each member including the team manager of the teams in first, second and third places.
- d) If there is a Challenge Trophy, this will be awarded to the NAC of the winning team for custody until the following Championship.
- e) The cost for the medals will be borne by the organiser of the Championships.

B.12.3

- a) In a World or Continental Championships with more than one contest category a classification may be made of the overall performance of the competing nations. This is established by taking the total scores of the three members of the teams in all of the contest categories (in the case of F2A, F2B, F2D the three best scoring members or in the case of F2C the three best scoring teams). The highest total wins the award. In the case of a tie, the nation with the lower sum of team place numbers, given in order from the top, wins. If still equal, the total of the best individual placings in each class will decide.
- b) If there is a Challenge Trophy, this will be awarded to the NAC of the winning team for custody until the following championship.
- c) There are no FAI medal or diploma awards assigned for this classification.

B.13. PROCESSING OF MODEL AIRCRAFT CHARACTERISTICS

- B.13.1. A competitor may interchange various parts as he wishes provided the resulting model conforms to the rules of the contest and that the parts have been checked before the start of the contest.
- B.13.2. Repairs are permitted provided that the model still conforms to the requirements of the rules and regulations.
- B.13.3. When, after official checking (for free flight, after registration of model specifications) a model is lost or damaged, the competitor shall have the right to present a further model and corresponding model specification certificate for checking up to one hour before the official starting time of the contest in that class. In any event, the competitor may have only the eligible number of models entered (see 4c, 2.3.1. and 4d, 4.2) at the start of the contest.
- B.13.4. The organiser must appoint at least two processing officials, who will process at random the important model characteristics of at least 20% of competing models during the official contest time.
- B.13.5. Results are subject to the re-checking of the characteristics of the first, second and third place winning models.
- B.13.6. Processing of Free Flight Model Aircraft- Class F1A, F1B, F1C and F1J.
 - a) Model specification certificates and corresponding models must be presented on arrival at the time of registration for the event. These models will be clearly marked for identification by the organiser.
 - b) Official processing of the model characteristics will not take place before the start of the contest.
 - c) Before the start and during the contest, the competitors have the right to have launching cables (F1A) and motors (F1B) and swept volumes of motors (F1C and F1J) officially checked.
 - d) Before the start and during the contest, the competitors have the right to have the minimum weight of their models checked.

B.14. PROTESTS

- B.14.1. All protests must be presented in writing to the Contest Director at the competition and must be accompanied by the deposit of a fee. The amount of this fee shall be the equivalent of CHF 50. The deposit is returned only if the protest is upheld.

B.14.2. Time limit for lodging protests:

a) Before the opening of the contest:

A protest against the validity of an entry, qualification of competitors, the contest rules, the flying and contest area, the processing of models, the judges or other contest officials, must be lodged at least one hour before the opening of the contest.

b) During the contest: a protest against a decision of the judges or other contest officials or against an error or irregularity committed during an event by another competitor or team manager must be lodged immediately.

c) After announcement of the results: any protest relating to the results must be submitted through the NAC within 15 days after announcement of the results by the organiser. If necessary this protest may be passed to the CIAM.

B.15. SAFETY PRECAUTIONS AND INSTRUCTIONS

The large majority of model flying today in most countries takes place as recreation rather than within a competition framework and sometimes on publicly accessible sites with little or no formal control. Any accident involving model aircraft may result in property damage, injury and possibly even death. Apart from the direct harm, a less obvious result is the poor image of model flying that comes from the media coverage of such incidents which leads to public antagonism and the loss of flying facilities.

While the following information is intended primarily for FAI competition flying, much of it can be applied both to national contests and recreational model flying.

B.15.1. Premise

It is of the utmost importance that all model flyers observe safety rules. Any accident caused by carelessness is a hindrance to the progress of model aviation.

Safety rules are not an obstacle to the enjoyment of model flying, they help to prove that model flyers are the responsible citizens they proclaim to be.

It is not a sign of intelligence to show one's own skill among spectators. The flyer may know what he is doing but has no way of knowing what anyone else will do. So, it is to his personal benefit to make certain that no action on his part will result in an accident. It is therefore very important not to fly any model aircraft in competition or in the presence of spectators until it has been proved airworthy.

B.15.2. Competence

The following officials are competent to apply and enforce safety rules:

the Jury;

the Contest Judges;

the Contest Director;

the Circle Marshals;

the Flight Line Director;

the Processing Officials;

all officials of the Organising Body.

B.15.3. Prohibited

a) Metal-bladed propellers and rotor blades;

b) Repaired propellers and rotor blades;

c) Improperly mounted engines;

d) Knife-edge leading edges;

e) Sharp spinners or propeller fasteners;

f) Non shock-mounted radio equipment, where there is engine vibration;

g) Any ballast or heavy parts subject to jettisoning;

h) Any burning fuse that is not enclosed in a snuffer tube or similar device to retain and extinguish it.

B.15.4. Required

- a) The model should bear an identification of the owner.
- b) All spinners and other forward-facing metal or equally rigid projections should have a minimum radius of 5 mm.

B.15.5. Pre-flight Checks

Immediately before each flight, the flyer must verify the actual condition and the proper functioning of all parts contributing to efficient and safe flight of the model and the proper fitting and fixation of the various parts, with special reference to engines and propellers.

Models that have not been tested and proven airworthy must not be flown in the presence of spectators. Endeavour to conduct all flights in a manner that avoids danger to spectators and other flyers.

B.15.6. Immediately after the competitor has launched his model, he must leave the starting area, remove his equipment, and in the case of gliders wind up his launching cable.

B.15.7. Flying Sites

It is imperative that all flying sites be situated sufficiently far from power lines.

The starting area must be carefully chosen in such a way that adequate safety to persons and property be granted. The points to be considered in this context are: wind strength and direction, relative position of buildings, runways, vehicle parking and spectators areas, and the area where the models are assumed to land after a normal flight, according to the wind.

Flying sites in the vicinity of an airport or airfield, especially along the landing path, can be chosen as contest venues only with the permission of the airport operator and in full compliance with its safety rules and requirements.

B.15.8. Penalties

All dangerous models must be excluded from a competition. For any action against the Safety Rules, the penalties listed in the Sporting Code General Section apply.

B.16. DISQUALIFICATION FROM THE CONTEST

B.16.1. All competitors making use of a model, equipment or fuel which does not conform in all respects to the rules and regulations of the contest or which have not been verified by the organisers shall be disqualified from the contest.

B.16.2. Disqualification must be applied after any action contrary to article B.13.

B.16.3. The Jury shall notify the Team Manager immediately and quote the reasons for disqualification.

B.17. FAI CHAMPIONSHIP TROPHIES

B.17.1. Custody

All trophies which have been adopted by the CIAM as awards to individual or team winners of championships shall be considered to be in the custody of the FAI.

B.17.2. Ownership

Dependent upon the terms of presentation, trophies shall be considered the property of either the FAI or the donor. A schedule of ownership shall be maintained by the FAI Office.

B.17.3. Award

Trophies shall be awarded bi-annually. In those instances where for any reason a trophy is not awarded over a period of five years, custody of the trophy shall revert to the donor.

B.17.4. For purposes of identification, the holder shall be the National Airsports Control concerned.

B.17.5. Holders of the trophies shall be responsible for:

- a) Maintaining the trophy in good condition.
- b) Engraving the name of the winner and date of award in the manner established by previous winners.
- c) Insurance against loss for the period during which it is held.
- f) Delivery of the trophy to the organisers of the next championships to the address and by the date requested by the organisers. Should no request be made, the trophy shall be delivered to the NAC of the organisers at least six weeks prior to the date of the championships.
- g) The cost of transporting a trophy to the organisers of the Championships shall be responsibility of the NAC holding the trophy.

B.17.6. Collection of Trophies

Organisers of championships shall be responsible for:

- a) Requesting delivery of trophies by a specific date and to a specific address from the NAC concerned.
- b) Supply of duplicate copies of all correspondence and the name and address of the subsequent trophy holder to the FAI Office and the CIAM Secretary.
- c) Obtaining the signature of the team manager of the receiving team on the trophy report (See Annex A.2).

B.17.7. Registration of Trophies

The CIAM Bureau shall keep a master register of trophies listing the holders, donor and giving terms of presentation and acceptance. This register shall be maintained by the CIAM Secretary, and brought up to date each year, no later than at the CIAM Plenary Meeting.

B.17.8. Acceptance of Trophies

Donors of trophies considered to be "Perpetual" (i.e. remaining the property of the FAI or the donor) and proposed for award at championships shall declare their intent to the CIAM not later than the date of closure for the agenda each year. Acceptance of the trophy shall be conditional on a majority vote in favour by members of the CIAM.

B.17.9. Loss

In the event of loss or failure to award championship trophies, organisers of championships must present a statement of circumstances to the CIAM and propose replacement which shall be at the consideration of the donor of the original trophy and the CIAM.

ANNEX B.2

NATIONAL IDENTIFICATION MARKS

This listing does not imply that the countries listed are current FAI member organizations.

AFG	Afghanistan	CIV	Cote d'Ivoire
AHO	Netherlands Antilles	CMR	Cameroon
ALB	Albania	COD	Democratic Republic of the Congo
ALG	Algeria	COK	Cook Islands
AND	Andorra	COL	Colombia
ANG	Angola	COM	Comoros
ANT	Antigua and Barbuda	CPV	Cape Verde
ARG	Argentina	CRC	Costa Rica
ARM	Armenia	CRO	Croatia
ARU	Aruba	CUB	Cuba
ASA	American Samoa	CYP	Cyprus
AUS	Australia	CZE	Czech Republic
AUT	Austria	DEN	Denmark
AZE	Azerbaijan	DJI	Djibouti
BAH	Bahamas	DMA	Dominica
BAN	Bangladesh	DOM	Dominican Republic
BAR	Barbados	ECU	Ecuador
BDI	Burundi	EGY	Egypt
BEL	Belgium	ERI	Eritrea
BEN	Benin	ESA	El Salvador
BER	Bermuda	ESP	Spain
BHU	Bhutan	EST	Estonia
BIH	Bosnia and Herzegovina	ETH	Ethiopia
BIZ	Belize	FIJ	Fiji
BLR	Belarus	FIN	Finland
BOL	Bolivia	FRA	France
BOT	Botswana	FSM	Federated States of Micronesia
BRA	Brazil	GAB	Gabon
BRN	Bahrain	GAM	Gambia
BRU	Brunei Darussalam	GBR	Great-Britain
BUL	Bulgaria	GBS	Guinea-Bissau
BUR	Burkina Faso	GEO	Georgia
CAF	Central African Republic	GEQ	Equatorial Guinea
CAM	Cambodia	GER	Germany
CAN	Canada	GHA	Ghana
CAY	Cayman Islands	GRE	Greece
CGO	Congo	GRN	Grenada
CHA	Chad	GUI	Guinea
CHI	Chile	GUM	Guam
CHN	People's Republic of China	HKG	Hong Kong, China

HUN	Hungary	NZL	New Zealand
INA	Indonesia	OMA	Oman
IND	India	PAK	Pakistan
IRI	Islamic Republic of Iran	PAN	Panama
IRL	Ireland	PAR	Paraguay
IRQ	Iraq	PER	Peru
ISL	Iceland	PHI	Philippines
ISR	Israel	PLE	Palestine
ISV	Virgin Islands	PLW	Palau
ITA	Italy	PNG	Papua New Guinea
JOR	Jordan	POL	Poland
JPN	Japan	POR	Portugal
KAZ	Kazakhstan	PRK	Democratic People's Republic of Korea
KEN	Kenya	PUR	Puerto Rico
KGZ	Kyrgyzstan	QAT	Qatar
KOR	Korea	ROM	Romania
KSA	Saudi Arabia	RSA	South Africa
KUW	Kuwait	RUS	Russia
LAO	Laos People's Democratic Republic	RWA	Rwanda
LAT	Latvia	SAM	Samoa
LBA	Libyan Arab Jamahiriya	SEN	Senegal
LBR	Liberia	SEY	Seychelles
LCA	Saint Lucia	SIN	Singapore
LIB	Lebanon	SKN	Saint Kitts and Nevis
LIE	Liechtenstein	SLE	Sierra Leone
LTU	Lithuania	SLO	Slovenia
LUX	Luxembourg	SMR	San Marino
MAS	Malaysia	SOL	Solomon Islands
MDA	Republic of Moldova	SOM	Somalia
MDV	Maldives	SRI	Sri Lanka
MEX	Mexico	STP	Sao Tome and Principe
MGL	Mongolia	SUD	Sudan
MKD	Former Yugoslav Republic of Macedonia	SUI	Switzerland
MLT	Malta	SUR	Suriname
MON	Monaco	SVK	Slovakia
MRI	Mauritius	SWE	Sweden
MTN	Mauritania	SWZ	Swaziland
MYA	Myanmar	SYR	Syrian Arab Republic
NAM	Namibia	TAN	United Republic of Tanzania
NCA	Nicaragua	TGA	Tonga
NED	Netherlands	THA	Thailand
NEP	Nepal	TJK	Tajikistan
NGR	Nigeria	TKM	Turkmenistan
NIG	Niger	TOG	Togo
NOR	Norway	TPE	Chinese Taipei
NRU	Nauru	TRI	Trinidad and Tobago

TUN	Tunisia
TUR	Turkey
UAE	United Arab Emirates
UGA	Uganda
UKR	Ukraine
URU	Uruguay
USA	United States of America
UZB	Uzbekistan
VAN	Vanuatu
VEN	Venezuela
VIE	Vietnam
VIN	Saint Vincent and the Grenadines
YEM	Yemen
YUG	Yugoslavia
ZAM	Zambia
ZIM	Zimbabwe

SECTION 4C – MODEL AIRCRAFT

PART ONE - GENERAL REGULATIONS FOR MODEL AIRCRAFT

1.1. GENERAL DEFINITION OF MODEL AIRCRAFT

A model aircraft is a heavier-than-air craft of limited dimensions, with or without a propulsion device, not able to carry a human being and to be used for competition, sport or recreational purposes rather than unmanned aeronautical vehicles (UAV) developed for commercial or governmental, scientific, research or military purposes.

1.2. GENERAL CHARACTERISTICS OF MODEL AIRCRAFT

Unless otherwise stated, model aircraft shall meet the following general specifications:

Maximum flying weight with fuel	25 kg
Maximum surface area	500 dm ²
Maximum loading	250 g/dm ²
Maximum swept volume of piston motor(s)	250 cm ³
Electric Motors power source max. no load voltage	42 volts

Noise limits shall be applied to powered model aircraft categories, with 96 dB(A) at 3 metres for any category which does not have approval for any other noise rule. Specific noise measuring procedures are to be developed by each subcommittee for its category.

Noise limits do not apply to model aircraft with electric motors.

1.3. CLASSIFICATION OF MODEL AIRCRAFT

1.3.1. Category F1 - Free Flight

This is a flight during which there exists no physical connection between the model aircraft and the competitor or his helper. Radio control functions are allowed only when specifically stated in the rules for the relevant class. Closed loop control systems with active sensors and operating aerodynamic flight controls are not allowed, except for steering in F1E.

Class:	F1A	- GLIDERS
	F1B	- MODEL AIRCRAFT WITH EXTENSIBLE MOTORS "Wakefield"
	F1C	- POWER MODEL AIRCRAFT
	F1D	- INDOOR MODEL AIRCRAFT
	F1E	- GLIDERS WITH AUTOMATIC STEERING
	F1F	- HELICOPTERS
	F1G	- MODEL AIRCRAFT WITH EXTENSIBLE MOTORS "Coupe d'Hiver"
	F1H	- GLIDERS
	F1J	- POWER MODEL AIRCRAFT
	F1K	- MODEL AIRCRAFT WITH CO ₂ ENGINES
	F1L	- INDOOR EZB MODEL AIRCRAFT
	F1M	- INDOOR BEGINNER'S CLASS
	F1N	- INDOOR HAND LAUNCH GLIDERS

1.3.2. Category F2 - Control Line Circular Flight

This is a flight during which the model aircraft is manoeuvred by control surfaces in attitude and altitude by the pilot on the ground by means of one or more inextensible wires or cables directly connected to the model aircraft. Devices in which the control wires or cables are held in the hand or connected to a central pivot may be used. No other means of controlling the model or the engine may be employed during the takeoff and flight except that exercised by the pilot through the line or lines.

- Class: F2A - SPEED MODEL AIRCRAFT
- F2B - AEROBATIC MODEL AIRCRAFT
- F2C - TEAM RACING MODEL AIRCRAFT
- F2D - COMBAT MODEL AIRCRAFT

1.3.3. **Category F3 - Radio Controlled Flight**

This is a flight during which the model aircraft is manoeuvred by control surface(s) in attitude, direction and altitude by the pilot on the ground using radio control.

- Class: F3A - AEROBATIC POWER MODEL AIRCRAFT
- F3B - THERMAL SOARING GLIDERS
- F3C - HELICOPTERS
- F3D - PYLON RACERS
- F3F - SLOPE SOARING GLIDERS
- F3G - MOTOR GLIDERS
- F3H - SOARING CROSS COUNTRY RACING GLIDERS
- F3I - AERO TOW SOARING GLIDERS
- F3J - THERMAL DURATION GLIDERS

1.3.4. **Category F4 - Scale Model Aircraft**

A scale model shall be a scaled down replica of a heavier-than-air man-carrying aircraft.

- Class: F4A - FREE FLIGHT FLYING SCALE MODEL AIRCRAFT
- F4B - CONTROL LINE FLYING SCALE MODEL AIRCRAFT
- F4C - RADIO CONTROLLED FLYING SCALE MODEL AIRCRAFT
- F4D - FREE FLIGHT INDOOR SCALE MODEL AIRCRAFT; Extensible motors
- F4E - FREE FLIGHT INDOOR SCALE MODEL AIRCRAFT; CO₂ or electric motors
- F4F - FREE FLIGHT INDOOR SCALE MODEL AIRCRAFT; Peanut formula

1.3.5. **Category F5 - Radio Controlled Electric Powered Flight**

This category is divided into the following classes:

- Class: F5A - AEROBATIC MODEL AIRCRAFT
- F5B - MOTOR GLIDERS
- F5C - HELICOPTERS
- F5D - PYLON RACERS
- F5E - SOLAR MODEL AIRCRAFT
- F5F - 10 CELL MOTOR GLIDERS

1.4 **DEFINITIONS OF EXPRESSIONS USED FOR MODEL SPECIFICATIONS AND RULES**

1.4.1. **Surface Area (st)**

The surface area includes the total surface of the wings and that of the horizontal or oblique stabilising surface or surfaces. The surfaces taken for calculation are the orthogonal projection on to a horizontal plane of the surfaces in question with each surface at zero incidence.

When wings or stabilising surfaces are built into the fuselage of the model aircraft the surface taken into account shall include that area contained within the normal contours of the flight surfaces extended so as to meet at the plane of symmetry of the model.

1.4.2. **Weight**

The weight taken to determine the minimum loading and minimum weight is that of the complete model aircraft in flying order but without fuel.

1.4.3. **Loading**

When loading rules are applied the loading shall be defined at the weight in grams per square decimetre of surface area. (st)

1.4.4 **Ballast**

When it is necessary to use supplementary ballast to obtain the stipulated weight or adjust the position of the centre of gravity, this must be located internally in the model and fixed in a permanent manner. Its position must be inspected and approved by a recognised official after insertion. When movable ballast is used to adjust the position of the centre of gravity, the model must be of the weight specified without the movable ballast.

1.4.5. **Wingspan**

Wingspan is the maximum distance between two points terminating the wing.

1.4.6. **Extensible Motor**

Motor in which the energy is obtained by the torsion or extension of strands of elastic material.

1.4.7. **Piston Motor**

Motors in which the energy is obtained by the combustion or expansion of a fluid acting on one or more reciprocating or rotary pistons.

1.4.8 **Glow Plug Motor**

A glow plug motor uses a continuously incandescent element to provide ignition.

1.4.9. **Compression Ignition Motor**

A compression ignition motor is one in which the charge is ignited solely by the effect of compression. This may include a mechanical system specially provided to control compression when the engine is operating.

1.4.10. **Jet Reaction Motor**

Motor in which the energy is obtained by a combustion of a solid, liquid or gaseous fuel, or by the expansion of a fluid acting on a rotating or pulsating member. In the case of model aircraft driven by reaction motors, the following supplementary characteristics are imposed:

Maximum outside diameter of pulse-jet combustion chamber: 80 mm.

1.4.11. **Hand Launching**

This is effected by hand, the competitor or helper standing on the ground.

1.4.12 **Take-off**

The model must rise from the ground or water in the correct manner without any help from the pilot or mechanic.

1.4.13. **Landing**

The model is considered to have landed when it has first touched ground or water, or definitely terminated its forward movement.

1.4.14. **Seaplane**

This is an model aircraft which must take off from water, but without obligation to land on the water at the termination of the flight (like a hoax). Prior to the take-off, a flotation test of one minute must be imposed on each model during which it must float on the surface without external aid in normal take-off position.

1.4.15. **Helicopters, Free Flight**

A helicopter is a heavier than air model aircraft which derives all of its lift and horizontal propulsion from (a) power driven rotor system(s) rotating about a nominally vertical axis (or axes).

Fixed horizontal supporting surfaces up to 4% of the swept area of the rotor(s) are permitted. A fixed or controllable horizontal stabiliser up to 2% of the swept area of the rotor(s) is permitted. Ground effect machines (hovercraft), convertiplanes or aircraft which hover by means of propeller slipstream(s) deflected downward are not considered to be helicopters.

Specifications

Area: Maximum swept area of the lifting rotor(s) counting only once any area superimposed areas: 300 dm², except for coaxial helicopters whose rotors are farther than one rotor radius apart, in which case the total area of both rotors is counted.

Weight: Maximum 5 kg with fuel.

Piston motor swept volume: Maximum 10 cm³.

Rubber motor: No restrictions.

Note: Metal bladed rotors are prohibited.

1.4.16. Swept Volume

a) Reciprocating engine

Swept volume is calculated as:

Swept piston area x stroke = swept volume

Swept piston area is calculated by measuring the bore of the liner at the top dead centre.

The calculation of volume shall be truncated to two decimal places (0,01 cm³)

b) Rotary engine

Swept volume is calculated as:

$$0,325(C^2 - D^2).b$$

For meaning of the letters see figure

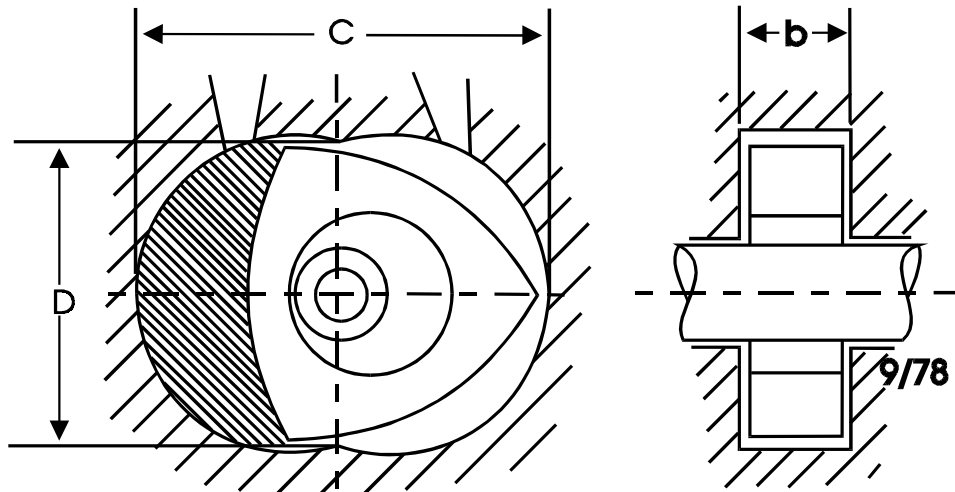

DISPLACEMENT CALCULATION OF ROTARY
PISTON ENGINE

PART TWO - GENERAL RULES FOR INTERNATIONAL CONTESTS

2.1 WORLD CHAMPIONSHIP EVENTS FOR MODEL AIRCRAFT

The following events are recognised as world championships for model aircraft (2001):

1. FF category:

- a) F1A Gliders
- b) F1B Model aircraft with extensible motors
- c) F1C Model aircraft with piston motors
- d) F1D Indoor model aircraft
- e) F1E Gliders with automatic steering

2. CL category:

- a) F2A Speed model aircraft
- b) F2B Aerobatic model aircraft

- c) F2C Team racing model aircraft
 - d) F2D Combat model aircraft
3. RC category:
- a) F3A Radio controlled aerobatic model aircraft
 - b) F3B Radio controlled thermal soaring gliders
 - c) F3C Radio controlled helicopters
 - d) F3D Radio controlled pylon racing model aircraft
 - e) F5B Radio controlled electric powered gliders
 - f) F5D Radio controlled electric powered pylon racers
 - g) F3J Radio controlled thermal duration gliders
4. Scale category:
- a) F4B Control line model aircraft
 - b) F4C Radio controlled model aircraft
5. Free Flight Junior category:
- a) F1A Gliders
 - b) F1B Model aircraft with extensible motors
 - c) F1D Indoor model aircraft
 - d) F1E Gliders with automatic steering
 - e) F1J Model aircraft with piston motors
6. CL Junior category:
- a) F2A Speed model aircraft
 - b) F2B Aerobatic model aircraft
 - c) F2C Team racing model aircraft
 - d) F2D Combat model aircraft
7. RC Junior category:
- a) F3J Radio controlled thermal duration gliders

2.2. ORGANISATION OF INTERNATIONAL CONTESTS

2.2.1. See Section 4b for details.

2.2.2. Special organisation requirements.

The organisers must:

- a) Provide a starting line in Free Flight contests for the classes F1A, F1B and F1C from which launching must take place. This starting line must be approximately at right angles to the prevailing wind direction at the start of each round.

Starting positions are indicated by markers, spaced at least 10 metres apart along the starting line. In the case of F1A, the helpers shall launch the model at this pole. Each country and the reigning champion, if not a member of his national team, is allotted a starting position for the first round by draw. In each successive round, all countries move three starting positions along the line in the same direction; upon reaching the end of the line, a country takes its next position at the other end of the line. Each competitor in the fly-off is allotted a starting position by draw for each fly-off round. Spectators are not allowed within 25 m from the starting line.

In Free Flight contests for class F1E, provide a starting line facing the wind with, on both ends, one perpendicular parallel line following the slope. The timekeepers have to remain behind the starting line whereas the competitor can launch his model in any position on the slope between the parallel lines. Provide a smooth flight area for R/C models to facilitate take-off and landing.

- b) Provide a protective wire enclosure at C/L speed and T/R contests 2,5 m high to ensure the safety of spectators. Circuit surface shall be firm, smooth and free of grit or dust. The radius of all circles shall be clearly marked

with a white line at least 25 mm wide. Provision of adequate practice areas shall be made before and during world championships.

2.3. PROCESSING OF MODEL AIRCRAFT CHARACTERISTICS AND NUMBER OF MODELS

2.3.1. The number of model aircraft eligible for entry are as follows

Class F4B, F4C	One (1) only
Class F2A, F2B, F3A, F3C, F5B, F3F, F3G	Two (2) only
Class F3D, F2C, F3B, F3J , F5D	Three (3) only
Class F1A, F1B, F1C	Four (4) only
Class F1E	Five (5) only
Class F1D, F2D	unlimited (two per heat in F2D)

2.3.2. Any model may only be used by one competitor during a competition.

2.3.3. The competitor may provide himself with spare propellers and rubber motors, piston motors, electric motors or gas turbines.

2.3.4. For categories F2, F3 (except F3A) and F4, all piston motors which might be used during the contest must be marked with an easily visible identification mark, details of which must be recorded at the time of checking the model. Motors which have been checked and recorded in this way may not be exchanged with other competitors.

2.3.5. Each NAC shall process every model entered for an international event (in accordance with the terms of 2.3.1.) and shall issue for each model a model specification certificate, provided by the FAI. A sticker, also provided by the FAI or marking to the pattern of this sticker, shall appear on each model. An example of how to fill out and handle the Model Specification Certificate and sticker is shown on the following pages.

2.3.6. Each model shall carry a model identification code (letters and/or numbers) and this must be recorded on the model specification certificate. The identification code is to appear on each part of the model aircraft (wing(s), tail, front and rear fuselage if detachable) so that the individual parts of a competitor's different models may be separately identified (except indoor and scale). The letters and/or numbers must be at least 10 mm high and clearly visible. The identification code of the nominated models (see para 2.3.1.) will be recorded on the score card.

2.3.7. Indoor model aircraft must bear an identity colour unique to the competitor within his team. Such colour marks must be made with ink or other essentially indelible chemical. All model aircraft must be marked before the contest.

2.3.8. Model aircraft not properly processed by their NAC, with FAI certificates and stickers, must be processed by the organiser at a cost of 10 Swiss Francs for each model.

Except for Indoor and Scale, each model must bear the nationality abbreviation of the International Olympic Committee and for Free Flight models the FAI licence number or the National Identification Number of the competitor. The letters or figures must be at least 25 mm high and appear at least once on each model (preferably on the upper surface of the left wing for Free Flight models). See Annex 2 in Section 4b and examples on the following pages.

External Identifications
Marques d'identification

Olympic Identity Marks
Immatriculation C.O.I.

FAI Sticker affixed
Étiquette FAI posée

Identification Code affixed
(on main parts)
Code d'identification (apposé sur les parties principales)

Motor(s) marked
Moteur(s) identifié(s)

Special requirements
Impératifs particuliers

(F.2.C., F.3.D.)
Cowling of Motor approved
Capotave du moteur approuvé

(F.2.B., F.3.A., F.3.D.)
Silencer fitted
Silencieux installé

Measurements
Mesures

(F.1.B., F.1.G.)
Rubber weighed
Moteur lastique pesé

(F.2.C.) Fuel Capacity
Capacité du réservoir

Flying weight with rubber motor
or fuel
Poids en ordre de vol avec moteur élastique ou carburant

(F.3.E.) Weight of Power Source
Poids de la source d'énergie

CHECKED BY
VERIFIÉ PAR

(Signed/signed)
(Signed/signed)
Date
Stamp of N.A.C.
responsable to F.A.I.
Cachet de l'O.N.C.S.A.
responsable

9. Measure
B. Verify
29/07/1995

Model identification code² 5
Code d'identification du modèle
First Name John
Prénom
FAI Licence Number 213564
Numéro de Licence FAI
I certify that this model fulfills all requirements as specified in the FAI Sporting Code Section 4 and 4a, and has been checked in accordance with the characteristics detailed below.

Je certifie que ce modèle remplit toutes les condition spécifiées dans le Code Sportif de la FAI, Section 4 et 4a, et qu'il a été contrôlé pour conformité avec les caractéristiques détaillées ci-dessous.



(Signed/signed) PETER Date 20/04/95

THIS SECTION TO BE COMPLETED BY THE NATIONAL AIR SPORT CONTROL
PARTIE A REMPLIR PAR ORGANISME NATIONAL DE CONTRÔLE DES SPORTS AÉRIENS

<i>All Classes (except F.1.D. Indoor Models) - Toutes classes (sauf F.1.D. modèles d'intérieur)</i>	
Wing Area - Surface alaire 12.1 dm2	Weight Limits* - Limites de poids* Minimum - Minimale 700 g Maximum - Maximale g
Tailplane Area - Surface de stabilisateur dm2	Wingspan - Envergure mm
Total Surface Area - Surface portante total 12.1 dm2	Weight - Poids g
(Class F.1.D. Indoor Models)(Classe F.1.D. modèles d'intérieur)	Fuselage Width - Largeur du fuselage 50 mm
Special requirements - Spécifications particulières	Fuel Capacity - Capacité du réservoir 6.0 cm3
(Class F.2.C. Team Racing) (Classe F.2.C. team racing)	Wingspan - Envergure mm
Fuselage Height - Hauteur du fuselage 102 mm	Wing Root thickness - Epaisseur de l'aile à l'emplanture mm
(F.1.G. Models with extensible motors) (Doupe d'Hiver)	Weight of Jet reactor Poids du réacteur g
Fuselage Cross Section - Maitre-couple du fuselage 41.5 cm2	
Wheel Diameter - Diamètre des roues 27 mm	
(Class F.2.A. Speed Models) (Modèles de vitesse)	
Minimum Surface Area for Swept Volume of Motor Surface portante minimale par unité de cylindrée dm2	
(Class F.3.D. Pylon Racing) (Classe F.3.D. course au pylône)	
Fuselage Height - Hauteur du fuselage mm	
Fuselage Width - Largeur du fuselage mm	
(Class F.1.F., F.3.C. Helicopters) (Hélicoptères)	
Sweep Area of Rotor(s) - Surface balayée du (des) rotor(s) dm2	
(Class F.3.E. Electric Powered Motor Gliders) (Planeurs à moteur électrique)	
Wheel Diameter - Diamètre des roues mm	
Weight of power source - Poids de la source d'énergie g	
(Classes F.1.C., F.1.F., F.2.A., F.2.B., F.2.C., F.2.D., F.3.A., F.3.C., F.3.D., F.4.A., F.4.B., F.4.C.)	
Swept Volume of the Piston Motor(s) Cylindrée totale du (des) moteur(s) cm3	

* Refer to specified characteristics. Weight limits are defined according to Class of Model either by specific minimum / maximum weight or by minimum / maximum loading of Surface Area, or in the case of F.1.C., by minimum power loading. In classes F.1.D., F.1.F., F.3.A., F.3.C., and F.3.D. there is no maximum loading.
* Se référer aux caractéristiques définies. Les limites de poids sont définies suivant la classe du modèle soit par des limites minimale et maximale de charge à la surface totale, ou dans le cas de F.1.C. par une charge minimale par unité de puissance. Dans le cas des classes F.1.D., F.1.F., F.3.A., F.3.C., et F.3.D., aucune charge maximale n'est imposée.
Example of filled out Model Specification

SUI NED

(Switzerland)..... (The Netherlands)

EXAMPLE OF NATIONAL IDENTIFICATION MARKS
 Ref. Section 4B, Annex 2 and Section 4c, para 2.3.9.

This mark should appear on the model aircraft at least once, and must be at least 25 mm high.

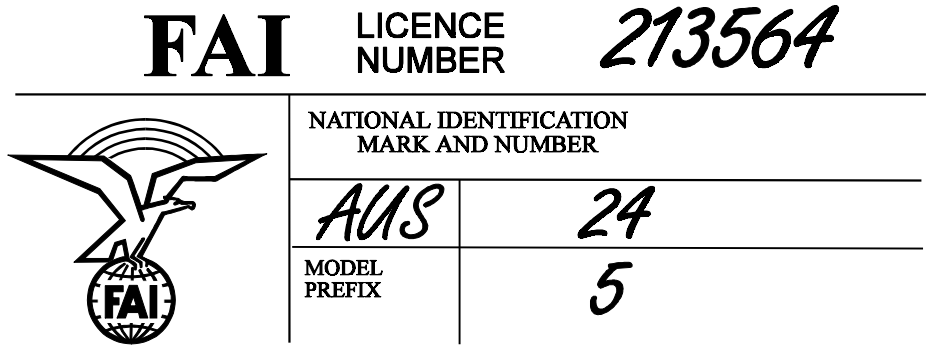
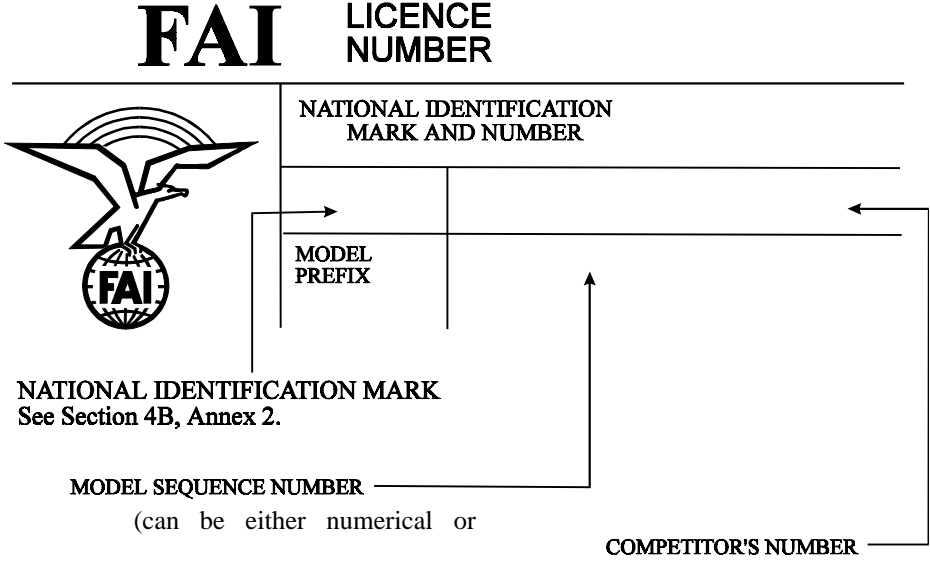

EXAMPLE

Note: Only ONE sticker per model required.

The sequence number (model prefix) should appear on each detachable main part of the model.

FAI MODEL AIRCRAFT STICKER

PART SEVEN - RECORDS

7.1. WORLD CLASS RECORDS:

7.1.1. The FAI recognises World class records in the categories of model aircraft listed in Table 1.

7.1.2. Holder(s) of Records.

A World record may belong to one person or a team. Where the record is in the name of more than one person, FAI will list those persons in alphabetical order, unless otherwise directed by the claimants' NAC. In the case of a team effort, the team shall comprise a maximum of three persons.

7.1.3. Builder of the Model Aircraft

In all records, the claimant(s) must be the builder(s) of the model aircraft flown in the attempt, except where the competition rules for the class exempt that class from rule B.3.1. The claimant(s) has/have to confirm this by his/their signature on form "Table II, Application for Record Confirmation".

7.1.4. Categories of World Records

There are three categories of World Records, viz:

- 1) Records performed with special record model aircraft under the specifications given in paragraph 7.2.; (Open Records)
- 2) Records performed with model aircraft built to competition specification but with flights not necessarily in a competition; (Specific Model Aircraft). These records can be set in classes F1D, F1L, F1M and F1N.
- 3) Records performed in regular competitions with model aircraft and competitions defined in Sporting Code section 4c, parts 1, 2, 3, 4 and 5; (Competition Records)

In Free Flight competition, duration records can be set in classes F1A, F1B, F1C, F1D and F1L.

In Control Line competition, speed records can be set only in World or Continental Championships in class F2A subclass 1B.

In classes F2C, F3D and F5D, records can be set only in World or Continental Championships.

7.2. GENERAL SPECIFICATIONS OF MODEL AIRCRAFT FOR RECORD ATTEMPTS:

7.2.1. Weight:

For records mentioned under 7.1.4, item 1), the total weight of the model aircraft in flying order, with fuel when carried, shall not exceed 5,00 kg. The maximum total weight in flying order with fuel of a helicopter shall not exceed 6.00 kg. For records in regular competition under 7.1.4. item 2), the model aircraft must comply with the specifications required for the class concerned.

No refuelling will be permitted after the model aircraft is airborne during any record attempt.

7.2.2. Motive Power:

The total swept volume of the piston(s) of the motor(s) shall not exceed 10 cm³. Pulse-jet reaction motor(s) are not permitted except for circular flight (record No. 30).

Power sources for electro models:

There will be four different possibilities of power sources:

F5 - "S" With rechargeable sources of current only (secondary elements).

F5 - "P" With non-rechargeable sources of current only (primary elements).

F5 - "SOL" Solar cells only permitted.

F5 - "COMB" All sources of current are allowed. All kinds of combinations are expressly allowed.

No connection between the source of current aboard the record model aircraft and the ground, or to another model aircraft or flying object is allowed.

There are no restrictions on the weight of extensible motors in model aircraft records.

Metal bladed propellers are not permitted.

7.2.3 Surface Area:

a) Fixed wing aircraft

a (1) For fixed wing aircraft the maximum surface area shall be 150 dm².

a (2) See 1.4.1

b) Rotary wing aircraft

See 5.4.1

7.2.4. Surface Loading:

For free flight model aircraft, the loading on the surface area (St.) must be between 12 g/dm² and 50 g/dm². For radio control model aircraft, the loading of the surface area must not exceed 75 g/dm². For control line model aircraft, the loading of the surface area must not exceed 100 g/dm². There are no area loading requirements or wing span restrictions for indoor model aircraft for record purposes.

7.2.5. Launching:

The model aircraft may be hand-launched or take off from the ground for record attempts in any category except seaplanes, the launcher standing on the ground. Aerotow is not permitted. Seaplanes must take off from a water surface.

For free flight a glider is launched by means of a cable of maximum 100 m in length. For radio controlled flight a glider is launched by means of a cable of 300 m maximum length. Launching of a glider may be carried out with the help of various devices such as winches, single or multiple pulley trains, or by running etc. To facilitate observation and timing the cable must be equipped with a pennant having a minimum area of 2,5 dm². All types of auxiliary stabilising devices are forbidden.

A parachute may be substituted for the pennant provided it is not attached to the glider and remains packed and inactive until the release of the cable.

The claimant must operate the launching device and must be standing on the ground, except for R/C gliders where an assistant may operate the device.

All freedom of action and movement is permitted to allow the best use of the cable length.

Auxiliary take-off devices, such as a cart or a dolly undercarriage are permitted for all model aircraft except seaplanes. No means of auxiliary power is permitted on such devices. The device may become airborne and subsequently ejected.

For seaplanes, the alighting gear must remain attached to the model throughout the flight.

7.2.6. Point of Landing:

The point where the model first touches the ground or water shall be considered the Point of Landing. It is not required that seaplanes land on water.

7.2.7. Jettisoning or Loss of Parts:

The voluntary or involuntary jettisoning of any part of the model aircraft, except auxiliary take-off devices, during the flight, is forbidden.

7.2.8. Assistant Pilots:

Following Rule 7.1.2, in case of a team effort, each member of the team may act as pilot during the attempt.

Note: In the event it is desired that a distance or duration record shall be listed in a single name only, an assistant pilot may be utilised after two hours from the start of the flight, up to a maximum of 10% of the total flight time recorded.

7.2.9. Difference Between Consecutive Records:

There is no minimum figure by which the old record should be exceeded.

7.2.10. Officials and Observers:

The head official shall be delegated by the National Airports Control of the country where the attempt is made and the attempt must be witnessed by a minimum of 2 additional observers who are approved by that National Airports Control.

7.2.11. Flying Site

Duration and Distance in Closed Circuit records for powered model aircraft (any power source) shall be made without the benefit of slope lift, over flat land or land with a maximum fall not to exceed 1 metre in 200 metres within 1 km of the course.

7.2.12. Repeated Record Improvements on the One and the Same Day.

On any date that a record is broken by more than one claimant, or repeatedly by the same claimant and model aircraft, the best performance only will be awarded the new record.

7.2.13. Safety

All Safety precautions and instructions of paragraph B.15 are applicable to record attempts

7.3. SPECIAL RULES FOR DURATION RECORDS

7.3.1. Recording the Time:

1. For all powered sub-classes the flying time starts at the moment when the model aircraft is released.
2. For model aircraft rising off the ground or water, the model aircraft must become airborne in a period that does not exceed 2% of the total flight time.
3. For all gliders, the timing starts when the glider is released from its launching device, or after hand launching.
4. For radio controlled model aircraft with piston engines or electric motors, the engine must be turning the propeller (fully unfolded if a folding propeller is fitted) for at least 98% of the time claimed as a record.

7.3.2. End of Flight:

The flight ends when the model aircraft touches the ground or water or encounters an obstacle which definitely terminates its flight, or when it definitely disappears from the sight of the timekeepers, or from the sight of any devices being used by the timekeepers to track the model. The use of optical devices, electronic devices and other means of proving the model remained airborne is permitted if approved by the National Airports Control.

For radio controlled models, the point of landing must be within a distance of 500 metres of the point at which the model was released from the ground during the launch.

In the case of a simultaneous record attempt for distance in a straight line and duration, the landing must be within 500 metres of the indicated landing point for distance record.

7.3.3. Timekeeping:

The time is taken by two timekeepers.

The times registered must be recorded in ink on the flight card at the scene of the record, and must be signed by the officiating timekeepers. Only these times will be officially recognised. To follow the model during the flight, the timekeepers are permitted to move by all means of locomotion available to them.

Recording barographs of the model aircraft may be used if they have received prior approval by the National Airports Control, in such cases the time which is established is that recorded by the barograph.

The loss in height between the starting and landing points must not exceed 2 metres for each minute of flying time.

7.3.4. Accuracy of Measurement:

For records only, electronic stopwatches of good quality (proof by certification) are to be used. A synchronous electric clock may be used as the standard of calibration.

Fractions of a second will not be retained in a time registered for a record flight.

7.3.5. Competition Records in Free Flight

Competition records are recognised for free flight models in competitions which have been registered on the FAI Sporting Calendar. All types of international contests are eligible: Open International, Limited International, Continental Championships, World Championships.

The durations to be considered for record purposes are as follows:

- a) For competition classes F1A, F1B and F1C, the total durations recorded in all official flights and fly-off flights. Records are not eligible from competitions which have flown more than seven official flights or if the maximum on any official flight was greater than the normal specified in paragraphs 3.1.7., 3.2.7., and 3.3.7. or fly-off maximum duration exceeding that specified in 3.1.8.b) and 3.1.8.d).
- b) in competition, records are recognised for duration in class F1D for:
 - i) the longest duration single flight;
 - ii) the longest total of the two best flights (as used for F1D classification);
 - iii) the longest total duration on all six competition flights.

For the purposes of Free Flight competition records, the National Airports Control of the claimant is responsible for lodging the record claim. The claim must be supported by data from the competition. The supporting documentation must include copies of the flight cards recorded at the competition and signed by the timekeepers of the flights. The director of the competition must certify that these records are authentic and certify that the model aircraft used in the record were processed in accordance with the Sporting Code.

For indoor competition records, there is no subdivision according to ceiling categories.

7.4. SPECIAL RULES FOR DISTANCE RECORDS IN A STRAIGHT LINE

7.4.1. There are two possibilities of setting a distance record in a straight line:

- a) Distance from A to B; and
- b) Goal and Return, that is, from A to B and back to A.

7.4.2. Measurement of Distance

The distance of the record shall be that measured in a straight line between the point of departure and landing, whatever may have been the actual path of the model aircraft.

In the case of Goal and Return record, the record distance is the distance from the starting point to turning point plus that from turning point to the landing point.

Distances up to 50 kilometres will be measured on an official map of a scale at least 1:100.000.

Distances up to 500 km will be measured on an official map at least 1:200.000 in Gauss/Krieger system

Distances greater than 500 km shall be calculated from the great circle of the verticals of the points at sea level. For purpose of this calculation, the terrestrial globe is considered as a sphere, the radius of which, adopted by the FAI, $r = 6371,0$ km. The exact position of the take-off point, landing point and turning point may be determined by GPS.

The dossier claiming the record must contain a detailed calculation, made by a recognised scientific body, of the distance, with reference to the geographical ordinates of the place of departure and arrival.

The degree of accuracy of the measurement must be stated in the dossier.

The distance shall be calculated to an accuracy of at least 1% for distances up to 500 km and 0.5% for distances in excess of 500 km.

7.4.3. Point of Departure:

For powered model aircraft the point of departure is the place where the model aircraft was released. For models rising off the ground or water, the distance covered in take-off cannot exceed 2,0% of the total record claimed.

For gliders, the point of departure is the place where the claimant is at the time when the glider is released from the launching device.

7.4.4. Point of Landing as Defined in 7.2.6.:

For radio controlled model aircraft, the pilot must indicate in writing before the flight the place where his model aircraft will land. The actual point of landing must be within a radius of 500 m of the point indicated.

7.4.5. For radio controlled model aircraft, the pilot may follow the model aircraft with his transmitter by any means of transport, the official observers accompanying him.

7.4.6. Turning Point

In case of Goal and Return distance record, the turning point must be as indicated as specified for the landing point in Rule 7.4.5. and the official observers must certify that the turning point has been properly rounded.

7.5. SPECIAL RULES FOR SPEED RECORDS IN A STRAIGHT LINE

7.5.1. Base:

For model aircraft of the Free Flight sub-classes, the record is measured over a base of 50 m for model aircraft with elastic type motors and of 100 m for model aircraft with piston type motors.

The course must be flown in both directions within 30 minutes.

For radio controlled model aircraft the base must be 200 m, and it must be traversed in both directions without any intermediate landing.

The altitude of the model aircraft must remain below 35 m and above 5 m during the 100 m entry and 200 m course. These altitudes are measured from the point where the pilot is standing.

The dossier of the record must include a certified measurement of the course and a statement of the methods used to determine altitude and speed.

For radio control speed record attempts the model aircraft must be fitted with a throttle or any other device to stop the motor by radio control.

7.5.2. Timing:

The timing of speed records must be effected by timing instruments approved by the National Airports Control.

The time is taken as the model aircraft enters and leaves the base.

Timekeeping must be effected by two timekeepers equipped with electronic stopwatches recording to at least 1/100 of a second. The difference between the times registered by the two time-keepers must not exceed 0.05 second. Automatic timing devices are allowed provided the system is properly documented in the dossier and approved by the NAC of the claimant.

For speeds above 300 km/h manual activation of timing devices is not permitted. Only automatic means of timing which eliminate the human error factor are permitted and must be certified accurate within 1/100 of a second.

The mean of the two speeds of the two runs over the timing base gives the record speed.

7.6. SPECIAL RULES FOR SPEED RECORDS IN A CLOSED CIRCUIT

7.6.1. **Base:**

The course consists of a square, defined by four prominently coloured pylons set 200 m apart on a 90⁰ angle to each other, situated on flat land, or land with a maximum fall not to exceed 1 metre in 200 m within 1 km of the course. Each pylon shall be consecutively numbered one through four. Using a line between Pylon One and Pylon Two as a base line, set Pylon Five (or a wire sighting device) midway between them (i.e. 100 m from each pole). At an angle of 90 degrees to the Base Line set Pylon Six 20 m distant from the Base Line. Place a 10 mm wide reflective (contrasting) strip of tape between Pylon Five and Six as the Start/Finish line.

Note: It is essential for accurate speed measurement that all pylons be absolutely vertical in order to prevent course length differences with altitude.

R/C gliders must be free of the launching cable (specified in 7.2.5.) prior to crossing the Start/Finish line. Models which land prior to completion of all four legs of the course, or intrude into the forbidden airspace (except after

timing is completed) are disqualified and the flight void. There is no altitude restriction or prohibition against circling in thermals outside the course.

7.6.2. Timing:

The timing of speed records must be effected by timing instruments approved by the National Airports Control.

Timing begins when the model aircraft crosses the Start/Finish line and ends when the model aircraft completes the course and again crosses the Start/Finish line still airborne within 30 minutes from launch.

Timekeeping must be effected by two timekeepers equipped with timepieces timing to at least 1/100 of a second. The difference between the times registered by the two timekeepers must not exceed 1/50 of a second.

Four judges will be situated immediately under each pylon and will raise a red flag when the model aircraft infringes the space bounded by the poles.

The pilot, his helper, timekeepers and the timing equipment must be located and remain during the record attempts inside the course at Pylon Five. Each pylon judge, also inside the course, will signal with a light when the nose of the model aircraft has passed the sighting device.

Each pilot may have one (1) helper who may launch or release the model aircraft for take-off and keep the pilot informed of the position of his model aircraft during the record attempt.

7.6.3. RC Pylon Race Time Record (10 laps):

Time records in pylon racing can be set over a ten lap course provided the record performance is achieved during a race under normal contest conditions in a world championship or a continental championship. The record figure will be the time recorded for completing the appropriate course.

7.7. SPECIAL RULES FOR SPEED RECORDS IN CIRCULAR FLIGHT

7.7.1. Base:

The speed will be timed over a minimum distance of one kilometre. Minimum flight circle must be:

Series 1A: Swept volume of motor 0 to 1,0 cm³ inclusive.R = 13,27 m (12 laps = 1 km)

Series 1B: Swept volume of motor 1,01 to 2,5 cm³ inclusive.R = 17,69 m (9 laps = 1 km).

Series II: Swept volume of motor 2,51 to 5 cm³ inclusive.R = 17.69 m (9 laps = 1 km).

Series III: Swept volume of motor 5,01 to 10 cm³ inclusive.R = 19,90 m (8 laps = 1 km).

Series IV: Jet reaction motors. R = 19,90 m (8 laps = 1 km)

Note: Longer lines may be used providing that the distance of one kilometre is made up by a whole number of laps.

7.7.2. Control Line(s):

For record attempts there shall be no limit to the diameter of the control line(s) or restrictions the construction of the control line(s).

7.7.3. Fuel:

There shall be no restriction to the composition of the fuel.

7.7.4. Timekeeping:

The timing must be carried out by two timekeepers using stop watches or timing apparatus registering to at least 1/10th of a second.

The difference between the two recorded times must not exceed 2/10th of a second.

The timing commences officially when the competitor has placed his handle in the pylon fork and the model, having made 2 complete circuits again passes the height marker on the edge of the circuit directly opposite the timekeepers.

The handle and pylon must conform to the specifications for control line speed contests except that in the case of single line control the competitor may use any handle with a single flexible point of attachment on the control handle and a horizontal bar (handle pivot) as for two lines handles, with a 6 mm maximum distance between the flexible point of attachment and the point of contact on the horizontal bar on the pylon fork.

Also for single line control systems, no rigid reinforcement of the line in front of the handle shall be permitted and any torsional, geared or other control mechanism must be positioned behind the pylon fork.

During the whole of the timed portion of the flight, the horizontal bar must rest in the pivoted fork, or the lines must be attached to a central pivot.

All physical effort for the purpose of increasing the speed of the model during a record attempt is forbidden and will entail immediate cancellation.

7.7.5. Height of Flight:

The normal flying height must be between 1 and 3 metres.

7.7.6. Accuracy of Measurement:

The speed recorded will be in kilometres per hour reduced to the nearest whole number below.

7.7.7. Team Race Speed Records Over 100 and 200 Laps (10 and 20 km):

Speed records in team race can be set over a 10 km (100 laps) course (normal race or semi-final) or a 20 km (200 laps) course (final) provided the record performance is achieved during a race under normal contest conditions in a World Championship or Continental Championship. The record figure will be the time recorded for completing the appropriate course.

7.8. SPECIAL RULES FOR ALTITUDE RECORDS

7.8.1. Verification of Measurements:

In order to establish the height above the starting point it is required:

- either to use small barographs made specially for model aircraft and carried on board; the barographs having previously been approved by the National Airsports Control.
- or, to ensure control by qualified observers using theodolites or telemeters, provided these instruments have been previously approved by the National Airsports Control.
- or, by means of a barograph carried in an aircraft which follows the model but never exceeds the maximum height of the model. An official observer must be present in the aircraft during the flight, and the barograph record must be counter signed by the official observer and the pilot of the aircraft.

If theodolites or telemeters are used, the National Airsports Control must give:

A description of the instruments and the methods employed in using them, a signed statement certifying the degree of accuracy reached and a check report on the instruments and the method used.

In the case of a barograph, the calibration must be performed against an absolute pressure gauge and the International Civil Aeronautics Organisation Pressure vs. Altitude Tables may then be used to compute altitude.

7.8.2. Point of Landing:

For radio controlled models, the landing must occur within a radius of 500 metres of the point of departure as described in 7.3.2. In the case of simultaneous attempts for distance and altitude, the landing must be made as described in 7.4.4.

7.9. SPECIAL RULES FOR DISTANCE IN CLOSED CIRCUIT RECORDS

7.9.1. For radio controlled models, the length of the circuit must be over a straight base of 500 m for piston/electro type motor models, and over a base of 100 m for gliders.

7.9.2. Fractions of a circuit will not be included in the record claimed.

7.10. DOSSIER OF A RECORD ATTEMPT

It is the purpose of homologation procedures and requirements to ascertain as well as possible, that a given model aircraft indeed attains the flight performance claimed and that the flight was made within the requirements and standards of this Sporting Code. The many factors involved in the flight require that adequate data be submitted to

confirm a record attempt. In unusual circumstances, FAI may request additional substantiating data to insure that these purposes have been achieved.

- 7.10.1. A dossier must be submitted to the FAI within 120 days of the Record Attempt. It shall include:
1. A completed official form as shown in Table II.
 2. A three view drawing of the model aircraft showing all basic dimensions and stating the scale of the drawing. Certification countersignature of the National Airports Control official is required.
 3. A photograph of the model aircraft. Certification countersignature by a National Airports Control official is required.
 4. A statement of supporting data as listed in 7.11 below.
 5. Properly filled out Table III, Record Dossier Check Form.
- 7.10.2. Photocopies of record dossiers are available, upon written request of a National Airports Control, at a fee of CHF 60 for dossiers up to 10 pages and CHF 6 for each additional page.

7.11. SUPPORTING DATA:

Whenever numerical limits are established for special categories, such as 7.3.2. for point of landing, duration of motor run, or as 7.4.3. for take-off run a measurement of these specific quantities should be stated in the supporting data section.

If barographs, special electronic devices, timing equipment, etc., are employed, a description adequate to ascertain the accuracy and validity of the devices must be included.

A statement must be made that all requirements for the specific categories were met.

Latitude and longitude of take-off and landing points, as well as mathematical calculations must be shown for records involving great circle distances.

A listing of all officials and participating observers shall be included. The supporting data sheet shall be signed by the directing official.

For historical purposes, a brief description of the flight is desired. Pertinent factors, such as weather, special equipment in the models or on the ground, or any unusual circumstances occurring during the flight will be of value. This section is not officially required but officials are encouraged to submit it on a separate sheet of paper for future reference.

- a) TIME-KEEPING 7.3.3 (Duration) 7.5.2. and 7.6.2. (Speed)
- Describe in brief, the method of timekeeping employed.
 - No. of watches
 - Position of timekeepers
 - Electronic equipment used
- b) BASE 7.4.1. (Distance) 7.5.1. (Speed) 7.6.1. and 7.9.1. (Closed Circuit)
- Describe in brief, the method of establishing the base measurement.
 - Measuring equipment
 - Method of marking base limits
 - Number of observers at base limits
 - Method of signalling, base to pilot

Supply a sketch of the course, defining base, turning points, marker poles, altitudes of base limits and position of officials relative to course.

ALL REQUIREMENTS OF ARTICLES 7.4.1, 7.8.1, 7.11 MUST ALSO BE OBSERVED AND RECORDED IN THE DOSSIER.

TABLE 1

CLASSIFICATION OF RECORDS

PAGE 1

Flight category	Type of model aircraft	Class	Method of propulsion	Duration	Distance in a straight line	Gain in altitude	Speed	
	Glider	Open		101	102	103		
F1 FREE FLIGHT	Aeroplane	Open	Extensible Motor	104	105	106	107	
		Open	Piston Motor	108	109	110	111	
	Glider	F1A		112 Duration in competition				
	Aeroplane	F1B	Extensible Motor	113 Duration in competition				
		F1C	Piston Motor	114 Duration in competition				
	Indoor Aeroplane				DURATION			
					Ceiling Cat I <8M	Ceiling Cat II 8<15 M	Ceiling Cat III 15<30 M	Ceiling Cat IV >30 M
		Open	Extensible Motor	115(a)	115(b)	115(c)	115(d)	
		F1D	Extensible Motor	125(a)	125(b)	125(c)	125(d)	
		F1L	Extensible Motor	116(a)	116(b)	116(c)	116(d)	
		F1M	Extensible Motor	117(a)	117(b)	117(c)	117(d)	
		F1N		118(a)	118(b)	118(c)	118(d)	
	Indoor Glider	F1N		118(a)	118(b)	118(c)	118(d)	
					DURATION IN COMPETITION			
				One Flight	Two Flights	6 Flights		
Indoor Aeroplane	F1D	Extensible Motor	119	120	121			
	F1L	Extensible Motor	122	123	124			
F2 CONTROL LINE CIRCULAR FLIGHT	Aeroplane				SPEED			
					SWEPT VOLUME cm ³			
					I	II	III	IV
					0,00 to 1,00	1,01 to 2,50	2,51 to 5,00	5,01 to 10,00
					130	131	132	133
		F2A				Speed in Competition		
					134			
			135					
F2C	Piston Motor	100 laps - 57*			200 laps - 58*			

*Only in World Championships & Continental Championship

CLASSIFICATION OF RECORDS

PAGE 2

Flight category	Type of model aircraft	Class	Method of propulsion	Duration	Distance in a straight line	Gain in altitude	Distance Goal and return	Speed	Distance in a closed circuit	Speed in a closed circuit
F3 RADIO CONT. FLIGHT	Aeroplane		Piston Mot.	141	142	143	144	145	146	147
	Seaplane		Piston Mot.	148	149	150	151	152	153	154
	Glider			155	156	157	158	159	160	161
	Helicopter		Piston Mot.	162	163	164	165	166	167	168
	Aeroplane	F3D	Piston Mot.							10 laps 83
F5 RADIO CONT. FLIGHT	Aeroplane		Elec Mot.S	171	172	173	174	175	176	177
			P	178	179	180	181	182	183	184
			SOL	185	186	187	188	189	190	191
			COMB	192	193	194	195	196	197	198
	Helicopter		Elec. Mot.	199	200	201	202	203	204	205
	Aeroplane	F5D	Elec. Mot.							10 laps 90

TABLE II
APPLICATION FOR RECORD ATTEMPT CONFIRMATION
MODEL AIRCRAFT

1. Numerical identification of record category:
 (From Table 1, Part Seven of FAI Sporting Code.)
2. Record figure claimed:
3. Date of record attempt:
4. Name(s) of claimant(s):
5. FAI Sporting License(s) No.:
6. Nationality:
7. Name of NAC:

8. Characteristics of Model Aircraft

Principal Dimensions: (Metric Units) _____

Total surface area _____

Weight without fuel _____

Weight with fuel _____

Minimum loading _____

Maximum loading _____

MOTOR

Electric motors:

Bore _____ Make/type

Stroke _____ Nominal capacity VA

Swept volume _____ Power source(s) P, S, SOL, COMB*

Make _____ Type of cells

No. of cells P: S: SOL:

Total working voltage _ V

* Encircle which is applicable

9. We, the undersigned, certify that all requirements of the Sporting Code for this category have been met to the best degree we can determine, including Rule 7.1.2.

Directing Official's Signature

Signature(s) of Claimant(s)

Certification by NAC Official

10. Enclosures:
 - a) three view drawing
 - b) photograph of the model aircraft
 - c) statement of all necessary supporting data

TABLE III
CHECKLIST RECORD DOSSIER- MODEL AIRCRAFT

WHEN PREPARING A WORLD RECORD DOSSIER PLEASE CHECK AGAINST THE LIST THAT ALL REQUIREMENTS HAVE BEEN MET.

In Check Mark column: If OK mark ✓, If not applicable mark -

ITEM No.	DESCRIPTION	CHECK MARK
0	GENERAL : FAI Office in Lausanne notified by email or fax within seven (7) days after the day the record was set.	
1	Form Table II completely filled out and properly signed (names also in block writing). DO NOT FORGET CERTIFICATION BY NAC OFFICIAL.	
2	Three-view drawing of model, certified by NAC Official (7.10.1.2).	
3	Photograph of model, certified by NAC Official (7.10.1.3).	
4	List of officials and observers, signed by Directing Official (7.11)	
5	Summary of all supporting data submitted with the dossier (7.10.1.4).	
6	All supporting data signed by Directing Official.	
7	Description of record attempt (7.11)	
7a	Claimant is the builder of the model (if applicable, see 7.1.2)	
8	DURATION RECORDS Flight card, showing both stopwatch readings entered in ink, signed by both time-keepers (7.3.3).	
9	Final record figure rounded off to lower whole second, discarding fractions of a second (7.3.4).	
10	Certificate on accuracy of stopwatches (7.3.4) or special timing devices (7.11).	
11	Statement that duration of take-off run of hydroplane does not exceed 2% of total flight time (7.3.1-7.11)	
12	Statement that duration of engine run of RC models is not less than 98% of total flight time (7.3.1-7.11)	
13	Statement on landing point for RC models (7.3.2).	
14	ALTITUDE RECORDS Barograph record signed by Directing Official (7.8.1).	
14a	If model has been followed by full size aircraft, barograph record should be countersigned by both the pilot and official observer (7.8.1)	
15	Barograph calibration record or calibration table.	
16	If theodolites were used, readings should be recorded and calculations of height must be submitted, signed by official observer.	
17	Description of special equipment used, include signed statement on accuracy.	
18	Statement on landing point for RC models (7.8.2).	
19	SPEED RECORDS IN STRAIGHT LINE (Free Flight and Radio Controlled) Flight card with both stopwatch readings of each of the two flights required (7.5.2), signed by the time-keepers and the Directing Official.	
20	Certificate on measuring of the speed course (7.5.1 and 7.11).	
21	Statement on method used to determine altitude and speed (7.5.1).	
22	SPEED RECORDS IN CIRCULAR FLIGHT (Control Line) Flight card with both stopwatch readings signed by the time-keepers and Directing Officials.	
23	Statement that line length is in accordance with the requirements of 7.7.1.	
24	DISTANCE RECORDS IN STRAIGHT LINE Official map showing record distance, take-off and landing points (7.4.1): at least scale 1:100.000 for distances up to 50 kms at least scale 1:200.000 in Gauss-Krieger system for distances from 50 to 500 km.	
25	Geographic coordinates of take-off and landing point (7.4.1 and 7.11).	
26	Calculation of record distance by Geographic Scientific Body including statement on degree of accuracy of the calculation (7.4.1) signed by the Directing Officials.	
27	Statement of actual landing point with reference to point of landing put down in writing before start of record attempt.	
28	DISTANCE RECORDS IN CLOSED CIRCUIT Description and sketch of arrangement of course (7.11b).	
29	Statement on measurement of base (7.11b).	
30	SPEED RECORDS IN CLOSED CIRCUIT Flight card with both stopwatch readings of the record flight signed by both time-keepers and the Directing Official.	
31	Description and sketch of arrangement of the course (7.11b)	
32	Statement on measurement of the base (7.11b).	